

# Accessories

## Electric Torque Screwdrivers



### TOOL CRIB Item #064000

Prevents broken or dropped tools. Reduces tool bench clutter. Easy operator access.

Mounts in a variety of positions on the work bench or the production line. The flexible ToolCrib can rotate to 8 locations.

Hole at the bottom of ToolCrib allows for a bit to pass through.

Crafted with durable aluminum.



Surface Mount



Under Table Mount

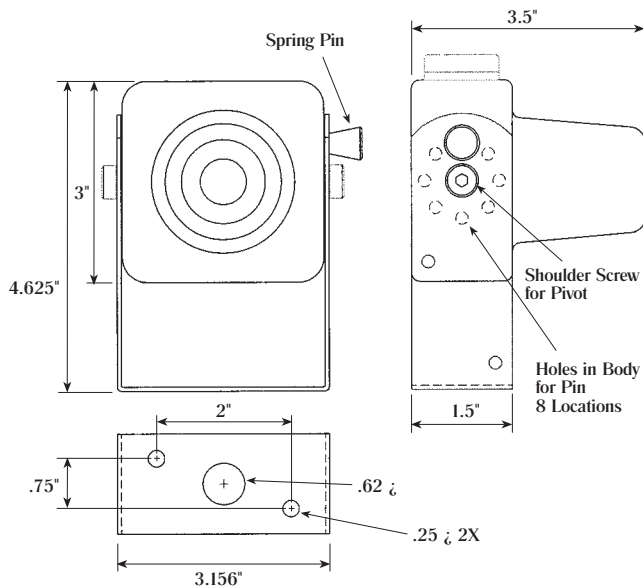

### MAG-O-NETS

Magnetize bits by sliding a Mag-O-Net onto the bit.

(actual size)



Desc.	Item #	Inner Dia.	Outer Dia.	Package Quantity	Use
for 3/16" Shank Bit	145710	3/16"	17.5mm	10	For most 0 & 00 bits
for 5mm Shank Bit	145711	6mm	17.5mm	10	Reduced Dia. Bits
for 1/4" Shank Bit	145712	7mm	19mm	10	Standard Bits

### Accessories

02.19



### MOUNTZ RIGHT ANGLE ADAPTER

Designed with an industrial strength pneumatic driver head. Robust and durable. Easily mounts onto nose of driver. Only operational with Lever Start 1/4" F/Hex driver models. Size 4-1/8" x 1-1/2".

#### Item # | Fits Driver Models:

067061	K-Series
067062	A4500, A5000, CL4000, SS4000
067063	A6500, CL6000, CL6500, CL7000, SS6500, SS7000
067064	VZ-Series
067065	EF-Series
067067	Delvo 7100/7200 Series
067068	Delvo 7500 Series
067069	E-Series



### HIOS RIGHT ANGLE ADAPTER

Only works with Lever Start 1/4" Female Hex drives. Keep torque output to within 70%. Threadstyle: 23.85 dia x 1.5mm pitch

Use with: A6500  
CL6000, CL6500, CL7000  
SS6500, SS7000

Size: 3" x 2-1/4"

Item # 144323



### PUSH-TO-START ADAPTER

Converts lever operated tools to Push-to-Start models.

A4500, A5000, CL4000, SS4000

Item # 144342

CL3000, SS3000

Item # 144343

Hex to HIOS



### DRIVE ADAPTERS

1/4" F/Hex Drive to 4mm HIOS Drive

Item # 144328

1/4" F/Hex Drive to 5mm HIOS Drive

Item # 144337

HIOS to Hex



4mm HIOS Drive to 1/4" F/Hex Drive

Item # 144327

5mm HIOS Drive to 1/4" F/Hex Drive

Item # 144332



### MAGNETIZER / DEMAGNETIZER

Magnetize or demagnetize bits and parts instantly.

Item # 120815

## PISTOL GRIPS

Converts inline drivers to pistol grip.



HIOS Models:  
A6500  
CL6000  
CL6500  
CL7000  
SS6500  
SS7000  
Item #144341

K-Series Models:  
K250  
K350  
K450

Standard  
Pistol Grip  
Attachment  
(for K-Series)  
Item #145713

ESD Pistol Grip Attachment  
(for K-Series ESD Models)  
Item #145714



## EXTENSION CORD

Combine with existing power cord.  
Works with A, BL, CL, EF, ESD,  
K or SS Series Drivers.

Length: 10 ft.  
Item #144180

Length: 16 ft.  
Item #144181



## COILED POWER CORD

Works with A, BL, CL, EF, ESD,  
K or SS Series Drivers.

Length: 4 ft. coiled (5 ft. extended)  
Item #41F9TR-8100

## TOOL STAND

A rugged adjustable tool support stand. Prevent tool damage due to dropping or mishandling. Convenient tool positioning - adjust both vertically and horizontally. Electric tool cords can be tie-wrapped to the vertical base to keep work station clean. 360 degree swivel. Four foot high, maximum arm length 1.75 feet. A balancer is recommended.

Model: MT-10  
Item #060050

## Pneumatic Center Block

Fitted with a pre-tapped plumbing holes. For attaching air fittings or air hose on MT-10 Tool Stand.

Item #061385



## BENCH CLAMP

Used to clamp MT-10 Tool Stand base to table tops. This handy unit eliminates hole drilling and secures the tool stand in place. It's flexible and ready to move at a moments notice.

Model: 311  
Item #180035

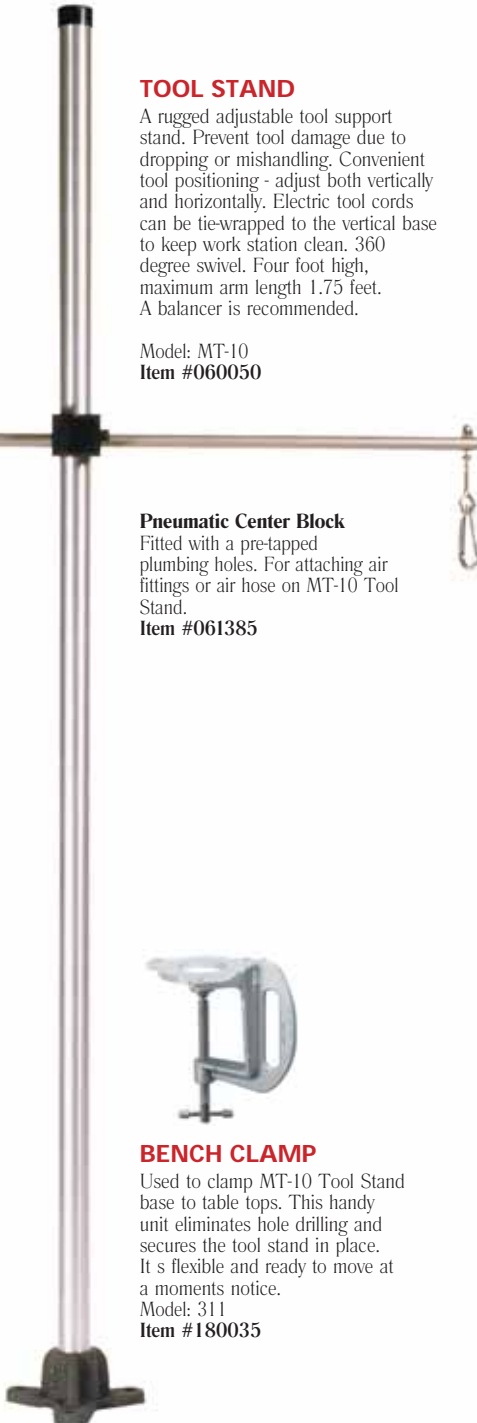

## DRILL CHUCK

Converts all 1/4" drive tools for drilling applications. Chuck capacity 1/4". Comes with chuck key.

Item #144331

## DRILL CHUCK KEY

Item #144336



## TORQUE BUSTER

Designed to reduce operator injuries resulting from the torque transmitted from the power tool to the hand of the operator. High user comfort, decreases injuries, works in all orientations, and fits most power tools

Item #144315



[etorque.com](http://etorque.com)