

DM 40 Click Wrench (Adjustable)

Rev. 1.0

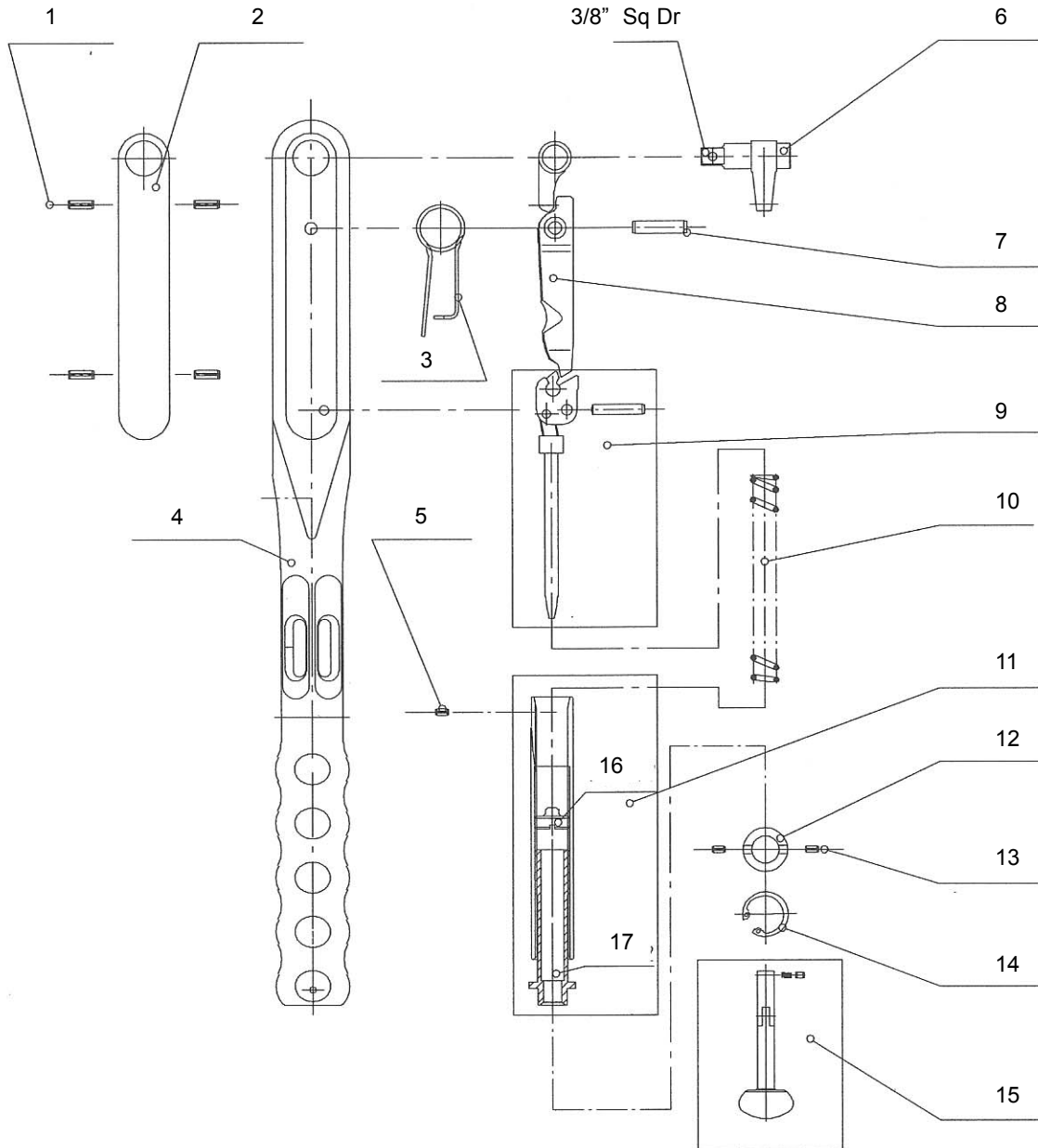

DM 40 Click Wrench (Adjustable)

Ref #	Part #	Quantity	Description
1	28-1180223	4	Dowel Pin ISO 8752 4x12
2	28-1180363	1	Lid DREMOMETER A
3	28-1184016	1	Wing spring A-E
4	28-1180339	1	Body DREMOMETER A compl.
5	28-1180215	1	Elastic pin 3x6
6	28-1182544	1	Primary Lever 3/8" A compl.
7	28-1183095	1	Cylindric pin DREMOMETER A-CD
8	28-1183427	1	Final Lever DREMOMETER A-E
9	28-1196685	1	Angle lever DREMOMETER A compl
10	28-1181351	1	Compression spring DREMOMETER A
11	28-1182561	1	Tube DREMOMETER A compl.
12	28-1189700	1	Thrust washer A-F
13	28-1180215	2	Elastic pin 3x6
14	28-1180258	1	Safety ring 22x1
15	28-1182382	1	Hexagon key DREMOMETER A-F (NEW) complete
16	28-1180177	1	8563-10 Adjusting screw
17	28-1180312	1	Spindle screw DREMOMETER B