

EZ-Glider

Telescoping Torque Arms



Driver not included.

KEY FEATURES

- Crafted with lightweight durable carbon fiber the arm collapses like a telescope.
- Easy-to-use, requires little space and doesn't disrupt production flow.
- The effortless handling of the torque arm provides comfortable tool operation and increased production.
- Mountable and easy to install on a wall, workbench and a standard rail or trolley system.
- Maintenance free.
- Eliminates torque reaction of power tools. Can be used with a variety assembly tools like, electric & pneumatic screwdrivers, angle nutrunners, pulse tools, pistol style tools, grinders, impact wrenches, drills, sanders, and percussion tools.
- Long arm reach capability up to 8 ft.
- Perfect for MVI applications.
- Universal Adapter included with EZ-12T, 30T, 80T & 140T models.
- Torque capacity up to 147.5 lbf.ft (200 N.m).

MOUNTING TO THE "STANDARD GLIDING RAIL SYSTEM"

The Telescoping Torque Arms can be mounted to the Standard Gliding Rail System (sold separately) and can be used in a variety of positions. For a vertical position it is necessary to install one additional item, an interface bracket (sold separately).



Standard Gliding Rail System	Working Distance/Item #					
	450mm	650mm	850mm	1050mm	1350mm	1850mm
	#260103	#260104	#260105	#260106	#260107	#260108

SLEEVE KIT (ACCESSORY)

Item # 260150

Connect Standard Gliding Rail System together.

INTERFACE BRACKET

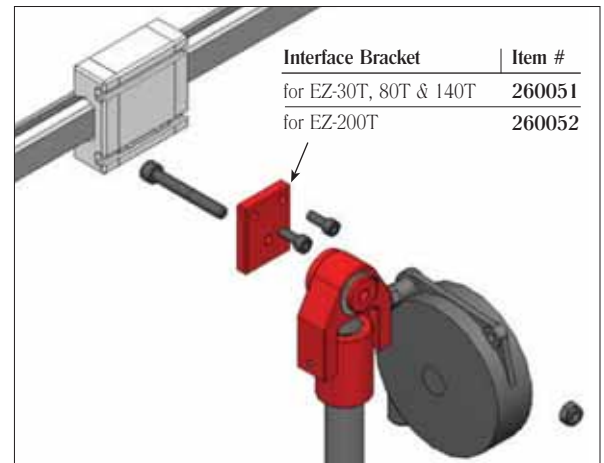

Interface Bracket	Item #
for EZ-30T, 80T & 140T	260051
for EZ-200T	260052

TOOL POSITIONING OPTIONS

Besides the standard in-line tool mounting position, the telescoping arm can be used with assembly tools in a variety of positions. For some tool positioning options, different tool clamp needs to be ordered separately.

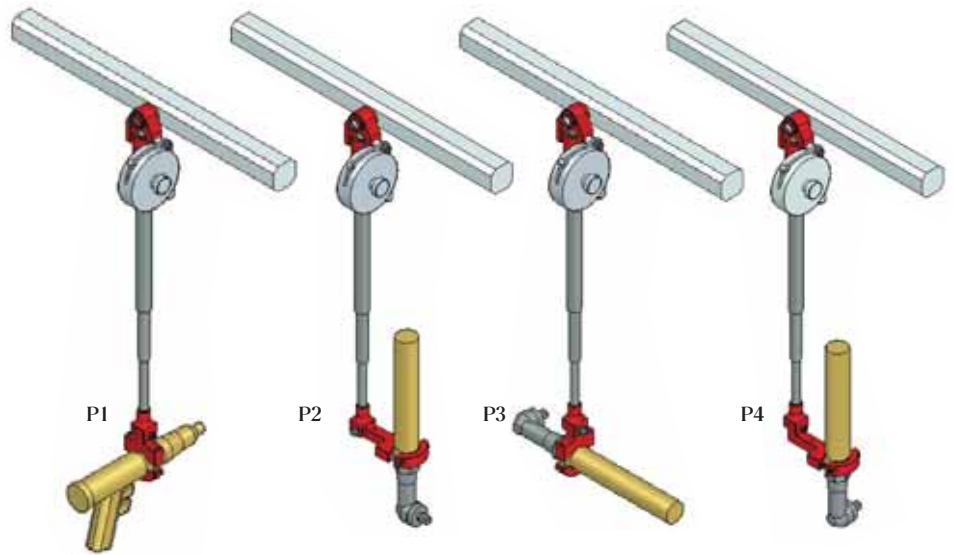
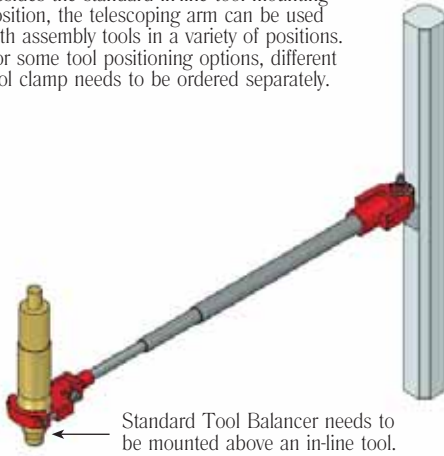

TELESCOPING TORQUE ARMS

Model	Item #	Max. Torque		Clamp Dia.	Min Arm Reach	Max Arm Reach	Weight of Arm	Tool Position Options			
		lbft.ft	N.m					P1	P2	P3	P4
EZ-12T	260075	8.8	12	1 - 1.5"	18.1"	37"	1.35 lbs.	Yes	No	No	No
EZ-12T/1500	260115	8.8	12	1 - 1.5"	25.6"	59"	2.7 lbs.	Yes	No	No	No
EZ-12T/2000	260116	8.8	12	1 - 1.5"	32.3"	78.7"	3.3 lbs.	Yes	No	No	No
EZ-30T	260076	22.1	30	1 - 2"	18.7"	37.5"	1.5 lbs.	Yes	Yes, Order Clamp #260145	Yes, Order Clamp #260144	Yes, Order Clamp #260146
EZ-30T/1500	260117	22.1	30	1 - 2"	25.8"	59"	3.3 lbs.	Yes	Yes, Order Clamp #260145	Yes, Order Clamp #260144	Yes, Order Clamp #260146
EZ-30T/2000	260118	22.1	30	1 - 2"	32.4"	78.7"	4 lbs.	Yes	Yes, Order Clamp #260145	Yes, Order Clamp #260144	Yes, Order Clamp #260146
EZ-30T/2500	260119	22.1	30	1 - 2"	39.1"	98.4"	4.4 lbs.	Yes	Yes, Order Clamp #260145	Yes, Order Clamp #260144	Yes, Order Clamp #260146

HIGH TORQUE TELESCOPING ARMS

Model	Item #	Max. Torque		Clamp Dia.	Min Arm Reach	Max Arm Reach	Weight of Arm	Tool Position Options			
		lbft.ft	N.m					P1	P2	P3	P4
EZ-80T/1500	260120	59	80	1 - 2"	28.1"	59"	6.6 lbs.	Yes	Yes	Yes	Yes, Order Clamp #260148
EZ-80T/2000	260121	59	80	1 - 2"	34.6"	78.7"	7.1 lbs.	Yes	Yes	Yes	Yes, Order Clamp #260148
EZ-80T/2500	260122	59	80	1 - 2"	41.3"	98.4"	7.7 lbs.	Yes	Yes	Yes	Yes, Order Clamp #260148
EZ-140T/1500	260123	103.3	140	1.25 - 2"	36.5"	59"	7.7 lbs.	Yes	Yes	Yes	Yes, Order Clamp #260148
EZ-140T/2000	260124	103.3	140	1.25 - 2"	46.4"	78.7"	8.4 lbs.	Yes	Yes	Yes	Yes, Order Clamp #260148
EZ-140T/2500	260125	103.3	140	1.25 - 2"	56.2"	98.4"	8.8 lbs.	Yes	Yes	Yes	Yes, Order Clamp #260148
EZ-200T/1500	260126	147.5	200	*	37.4"	59"	7.7 lbs.	Yes	Yes	Yes	Yes, Order Clamp #260149
EZ-200T/2000	260127	147.5	200	*	47.2"	78.7"	8.4 lbs.	Yes	Yes	Yes	Yes, Order Clamp #260149
EZ-200T/2500	260128	147.5	200	*	57.1"	98.4"	8.8 lbs.	Yes	Yes	Yes	Yes, Order Clamp #260149

* Customer must provide information (Brand & Model) on each tool being used with the arm. The clamp is custom made to fit the tool being used.

BALANCING KIT FOR VERTICAL MOUNTING

A balancing kit can be mounted on the side of any of telescoping arm. It allows the arm to be used with pistol grip tools and angle nutrunners (see tool position options above for using angle nutrunners with arms).

Model	Item #	Balancer Capacity	Stroke
E1	260140	2.2 - 4.4 lbs.	63"
E2	260141	2.2 - 5.5 lbs.	78.75"
E3	260142	4.4 - 8.8 lbs.	78.75"
E4	260143	8.8 - 13.2 lbs.	78.75"

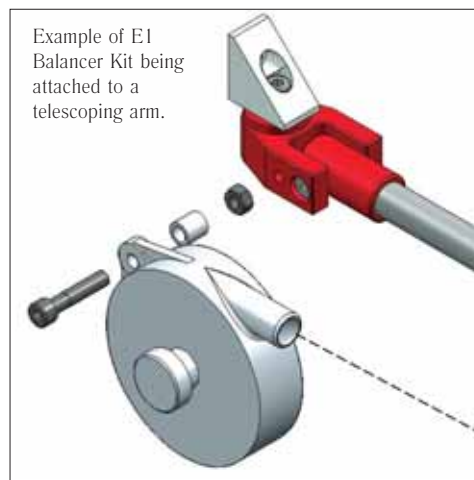

Example of E1 Balancer Kit being attached to a telescoping arm.



NOTE!

It is recommended to use a tool balancer with all EZ-Glider Telescoping Arm models. The telescoping arms should not be used at maximum arm reach on a permanent basis.