



# EZ-TorQ II

## Operating Instructions

Version 3.0  
September 21, 2011



Heading	Page
Screen Display	4
Mounting	4
Menu Selections (Units, Mode, Set-Up, Quick Test & Filter)	5-7
Enter Key & Mode Selection	7
Set-Up Selections (Direction, Data Output, Contrast, Language, Sleep, Backlight, Clear Memory, Auto Clear & Tolerance)	8-10
Filter Selections	11
External Connection	12
Power Tool Testing	12
EZ-TorQ Meter Interface Software	13-14
Com Port Selection	15
Quick Test Downloading	16
Data Logging	17
Bootloader	18
Battery Operation/Universal Charger	19
Accessories	20

## Features

- ❑ System Accuracy +/- 0.5% of reading from 20% to 100% of full scale.  
System Accuracy +/- 1% of reading from 10% to 20% of full scale.
- ❑ Recommended for hand screwdrivers, most wrenches and power tools\*
- ❑ Selection of three operating modes: (Track, Peak and First Peak\*)
- ❑ Seven units of torque measurements: (ozf.in, lbf.in, lbf.ft, cN.m, N.m, kgf.m, kgf.cm).
- ❑ Features built-in Quick Test operation.
- ❑ Includes PC Windows based software programs:  
**EZ-TorQ II Interface Program** - to conduct Quick Tool Tests, Data Logging and Sensor Calibration.
- ❑ "Flash" memory allows upgrades to be done by the user in the field & internet through the RS-232 port.
- ❑ Easy to use Menu Structure.
- ❑ Six-digit display.
- ❑ Ability to download readings to PC via RS-232 or via USB
- ❑ Real time out via RS-232
- ❑ High Capacity Li-Ion Batteries for long life.
- ❑ The unit will store a total of up to 150 data points.
- ❑ Real time graph of torque vs. time using associated PC Windows software.
- ❑ Features Go / No Go LEDs that illuminate when high or low tolerance setting is achieved or out of tolerance
- ❑ Three low-pass filter settings (500, 170 and 130 Hz)\*

\* Note! - Mountz added these features to the EZ-TorQ II operating system in September 2011. **EZ-TorQ II models prior to serial # EZ1108001** do not have these features. If you would like to have your EZ-TorQ II torque tester upgraded to include the current operating system, please send it to a Mountz Service & Repair facility.

1. New Operating mode: First Peak
2. New low-pass filter settings (500, 170 and 130 Hz)

# Quick Menu Structure

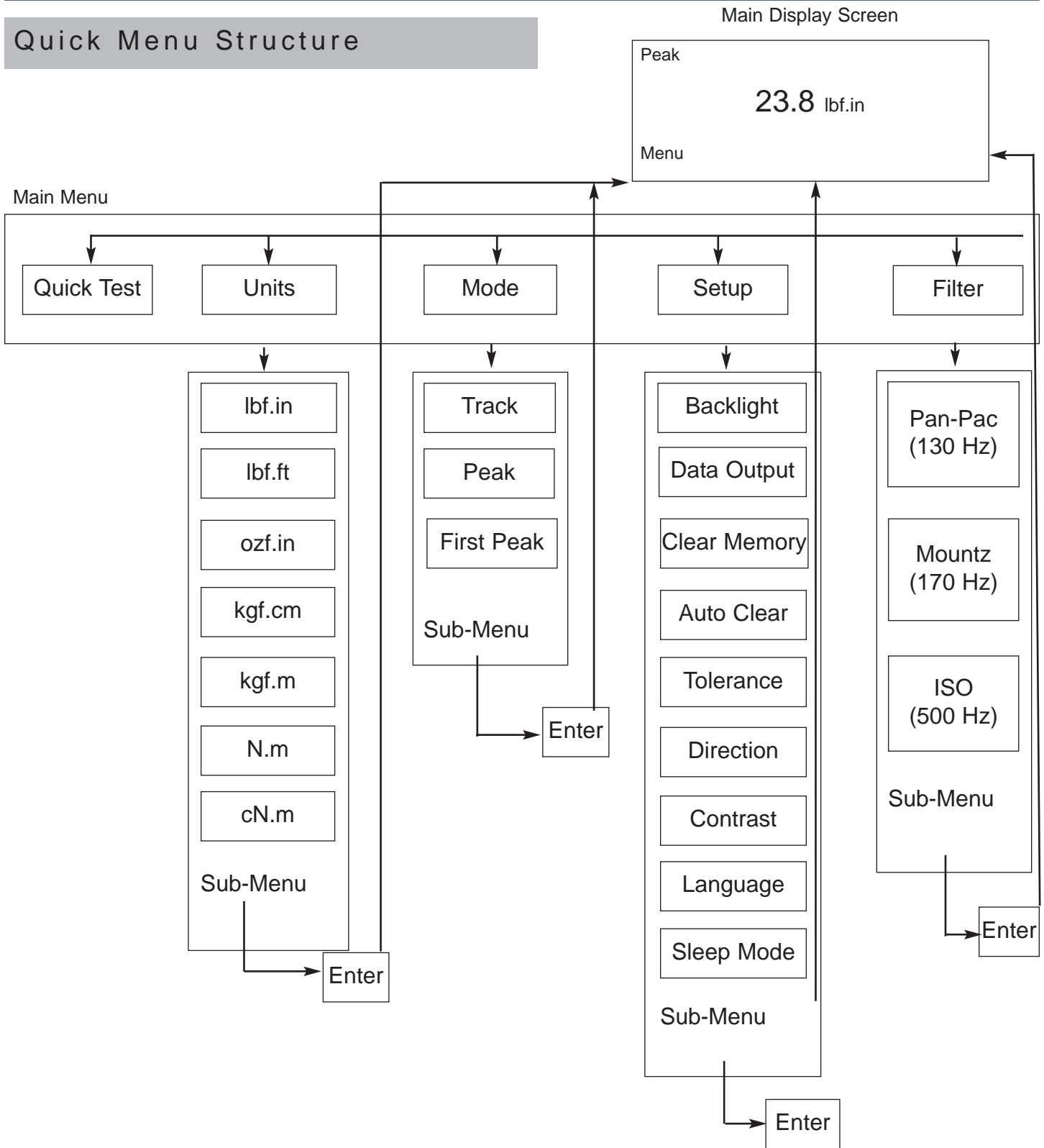

## Screen Display and Menu Structure

When the torque tester is turned on it will display a Screen similar to that below for 5 seconds and then go into Reading Mode.

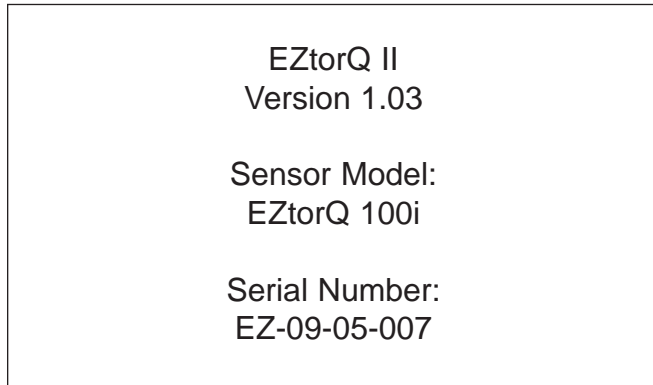

The Reading Mode Screen will appear as shown below:



The Menu key is used to access the available menu items. The scroll keys allow scrolling through various menu items. The Enter key is used to select a menu item and is also used to clear readings from the display if the unit is in Manual Clear mode.

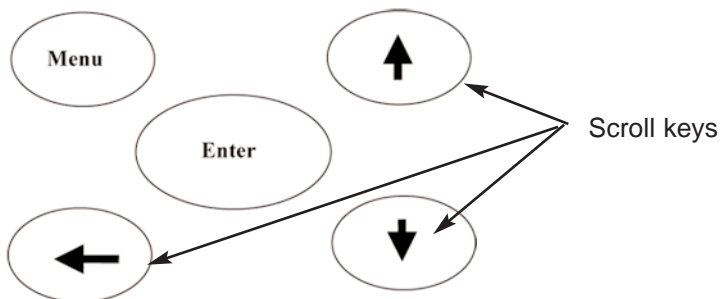

## MOUNTING

It is recommend securing the torque tester to a work-bench before operating. Immobilizing the analyzer is critical for the safety of the operator as well as for the accuracy of torque measurements during operation.

Mounting the unit to a fixed surface offers the most secure way to immobilize the analyzer, and is recommended when used at a permanent location. It employs two spring loaded mounting screws from the unit into the mounting surface.

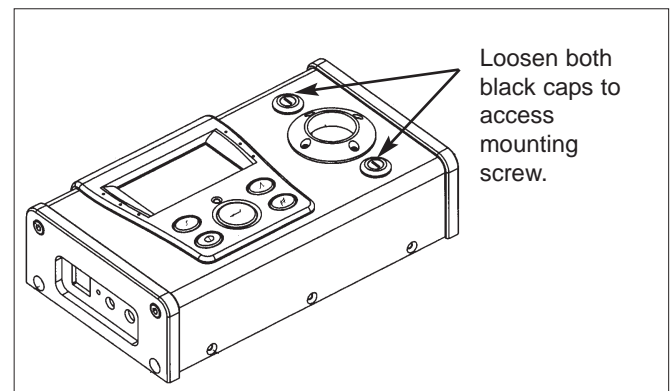

**Note:** Remember that a loose torque tester during utilization can impact the validity of torque readings. Always make sure the unit is secure before operating, as repeated usage may loosen the screws.

## Menu Selections

Pressing the "Menu" Key will present the following Screen:

1. Use the **Scroll Up or Down** key to toggle through: Quick Test, Units, Mode, Setup & Filter.
2. Press **Enter** key to select a choice.

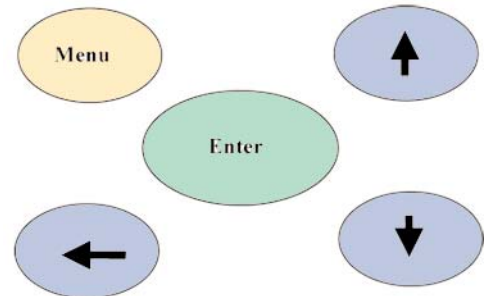
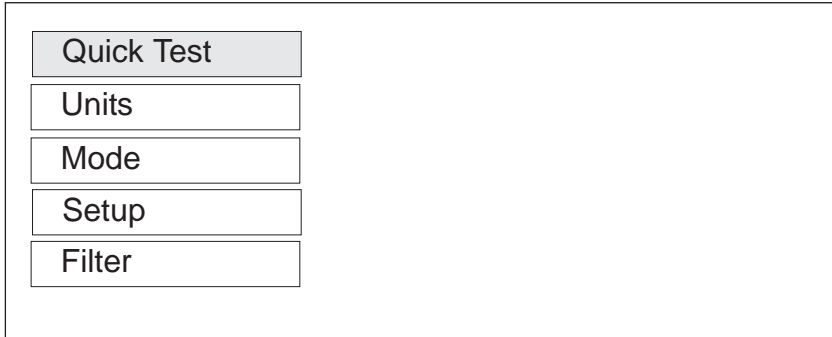

### Selecting Quick Test

Setup any operational parameters such as Auto Clear before starting a Quick test as settings cannot be changed during a Quick Test operation.

1. Press **Menu** button.
2. With the Quick Test selected, press **Enter** key

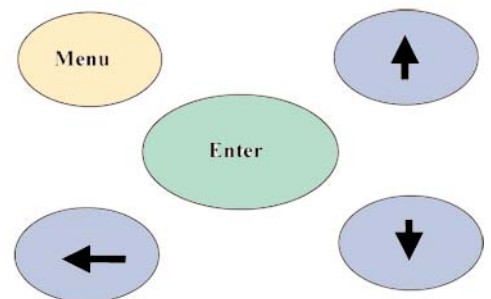
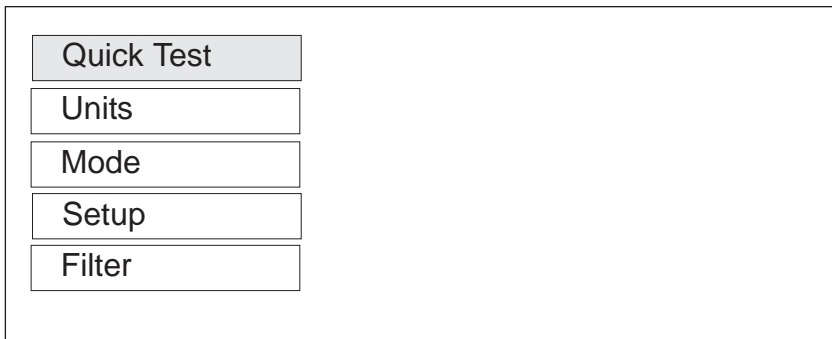

Once the Quick test is started the "Menu" indication at the bottom left of the EZ-TorQ screen will change to "Stop". When the desired number of readings are collected, press the Menu key to end the Quick test.

## Menu Selections

### Selecting Units

1. Select Units by highlighting and pressing **Enter**.
2. Use the **Scroll Up or Down** key to toggle through the Unit options.
3. Press **Enter** key to select a Units Setting.



**Note:**

cN.m is also available but you must scroll down.

Quick Test	lbf.in
Units	lbf.ft
Mode	ozf.in
Setup	kgf.cm
Filter	kgf.m
	N.m

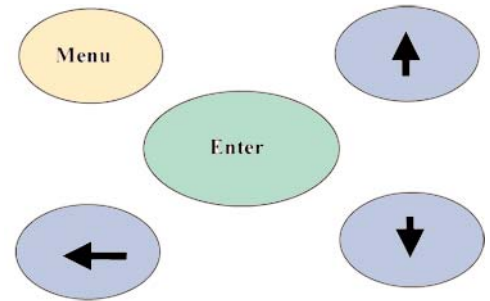

### Selecting Mode Options

1. Select Mode by highlighting and pressing **Enter**.
2. Use the **Scroll Up or Down** key to toggle through the Mode options.
3. Press **Enter** key to select a Mode Setting.
4. The Main (or reading screen) will display the value of the selected Mode.

Quick Test	
Units	
Mode	Track
Setup	Peak
Filter	First Peak

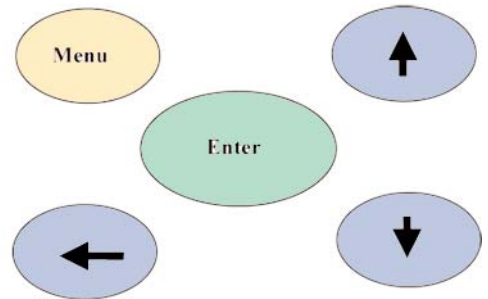

### Selecting Setup

1. Select Setup by highlighting and pressing **Enter**.
2. Use the **Scroll Up or Down** key to toggle through the Setup options.
3. Press **Enter** key to select a Setup Setting.



**Note:**

Contrast, Language & Sleep Mode is also available but you must scroll down.

Quick Test	Backlight
Units	First Peak
Mode	Data Output
Setup	Clear Memory
Filter	Auto Clear
	Tolerance
	Direction

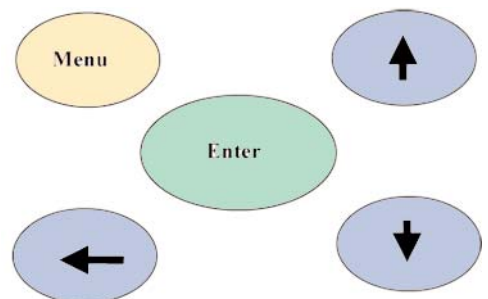

## Menu Selections

### Selecting Filters

1. Select Units by highlighting and pressing **Enter**.
2. Use the **Scroll Up or Down** key to toggle through the Filter options.
3. Press **Enter** key to select a Filter Setting.

Quick Test	
Units	
Mode	Pan-Pac (130 Hz)
Setup	Mountz (170 Hz)
Filter	ISO (500 Hz)

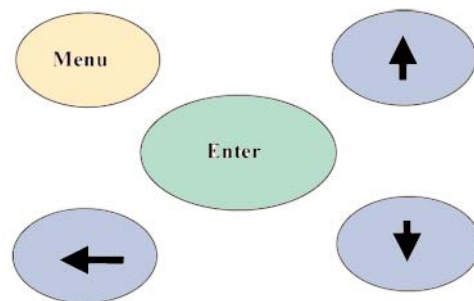

## Enter Key

The ENTER key function is used for two functions.

### **CLEARING DISPLAY**

The first function is used to clear any torque reading on the display. When the ENTER key is pressed it also sends the displayed reading to the RS 232 port for printing or downloading to an application program. After sending the data, the readings will automatically be cleared from the display.

### **VALIDATING SET-UPS**

The other function is the validation of user selection during set-ups (see the Mode Selection, Filter Selection, and the Units Selection).

## Mode Selection

The EZ-TorQ Torque Tester offers three different modes of displaying torque information during operation (Track, Peak and First Peak). The user will determine which mode is best suited for the application. The use of the three modes is described below.

### **TRACK**

This mode constantly tracks increasing or decreasing torque variations. Use this mode to monitor varying torque on motors and machinery. Also for calibration and testing of dial torque products (small wrenches or dial screwdrivers).

Track

**+12.010** Lbf.in

Menu

### **PEAK**

The display retains the highest torque applied. Use this mode during calibration or testing of any hand type torque wrench (dial, beam, and screwdriver), as well as power tools.

Peak

**+22.350** ozf.in

Menu

### **FIRST PEAK**

The display holds the first detected torque peak applied. Before any torque is applied, the display show dashes in the torque value area. Once peak is detected, the display will show the torque value. If a second peak is detected then it will be displayed in the lower right (in small reverse video).

The function of this mode is primarily used for testing and calibrating click type mechanical torque wrenches. The tester captures the point where the wrench first clicks. As additional force is applied a secondary torque is displayed. This mode may be used for operator training on the correct use of operating a click wrench. Always apply torque smoothly to avoid false first peak readings.

FPK

500 Hz

**+23.615** lbf.in

Menu

+24.755

## Setup Selections

### Backlight

This function allows the user to turn on the display backlight for low light environments.

Use the **Up / Down scroll keys** to select the desired setting and press **Enter** to select the setting.

BACKLIGHT SETTING

Backlight: OFF

## Setup Selections

### First Peak

This function allows a user to set up the First Peak settings.

Use the **Up / Down Scroll** keys to toggle between each setting.

Use the Scroll **Left** set up the data for each setting

Press enter to save the setting.

**Note!** The unit should never be plugged into the Mountz Interface Program with Data Output turned to "on".

First Peak  
Sensitivity: Low  
Min Peak: 5.0089 lbf.in  
Units: lbf.in

### Data Output

This function allows a user to toggle data output to On or Off. Defaults setting is Off.

Use the **Up / Down Scroll** keys to toggle the setting from Off to On. Press enter to save the setting.

**Note!** The unit should never be plugged into the Mountz Interface Program with Data Output turned to "on".

Data Output

**Off**  
On

### Clear Memory

This function clears the stored readings from Quick tests. The user will be asked if they really want to perform this function. If they do they must choose "Yes". The stored readings can also be deleted from the meter using the EZ Interface Program.

**Scroll** to Yes, if you truly desire to clear the readings, and press **Enter**.

Clear Tool Test Results  
Are You Sure?  
**Yes**  
No

### Auto Clear

This function controls the method of clearing the display of torque readings. When Auto Clear is selected, the torque values, during operation, will automatically be cleared from the display. The user can set the time threshold to control how long the values should be displayed before clearing. When Manual Clear is selected, the torque values during operation will indefinitely be display until the user presses the Enter key. The Auto Clear timer can be set from 1 to 5 seconds.

If a Quick Test is in operation, the readings will be stored when the Auto Clear timer expires or the user presses Enter if in Manual Clear mode.

Use the **Up / Down scroll keys** to change between Manual and Auto and press **Scroll Left** to move to the Time. Use the **Up / Down scroll keys** to select the Time. When finished, press **Enter** to end the process and store the setting.

AUTO CLEAR SETTING

Mode: MANUAL  
Time: (seconds) 1

## Setup Selections

### Tolerance

The Tolerance parameters control the Go and No-Go multicolored Green / Red LED and In Tolerance and Out of Tolerance indication on the meter screen. The user sets a lower and upper torque threshold to get a visual warning signal when these limits are reached or breached during operation.

When you first enter the Tolerance Setting screen Low Tolerance will be in reverse video. When this is true you can scroll between Low and High tolerance using the **Scroll Up / Down keys**.

To set the Tolerance press **Enter** and the value will change to normal video and the cursor will be on the last digit. Use the **Scroll Up / Down keys** to increase or decrease digits and **scroll left** to move to the next digit. When done with Low Tolerance press **Enter** and the Low Tolerance will appear in reverse video. Use **Scroll down** to move to High Tolerance and then press **enter** to edit the value. After completion press the **Menu key**.

#### TOLERANCE SETTING

Low: 10.000

High: 14.00

Units: Lbf.in

### Direction

Allows an operator to set the direction for capturing the torque readings: (Clockwise, Counter Clockwise and Both directions).

Use the **Up / Down scroll keys** to change between BOTH, CW and CCW. When finished, press **Enter** to end the process and store the setting.

#### DIRECTION SETTING

Direction: BOTH

### Contrast

This function sets the contrast of the Display.

Use the **Up scroll key** to increase the contrast and the **Down scroll key** to decrease the contrast. When finished, press **Enter** to end the process and store the setting.

#### SET LCD CONTRAST

Contrast: 60

### Language

The function allows the user to change the language of the meter. Only two languages are available in the meter at one time

Use the **Up / Down scroll keys** to change between languages. When finished, press **Enter** to end the process and store the setting.

#### LANGUAGE SETTING

Language: English

### Sleep

The meter will automatically turn off after 10 minutes of non use (no torque readings or no presses of the key pad buttons).

This function is used to turn off the sleep mode for users that do not want the meter to go to sleep.

Use the **Up / Down scroll keys** to change between sleep mode On / Off. When finished, press **Enter** to end the process and store the setting.

#### SLEEP MODE SETTING

Auto Sleep: On

**Caution:** The meter will have significantly less operational life if Sleep Mode is turned off.

---

## Filter Selections

The EZ-TorQ II product utilizes hardware level low pass filters prior to A/D conversion and software averaging to clean the main signal and remove undesired frequency signals which may be a result of noise which can occur during dynamic motion. Three filter settings are provided, as described below.

**1. Pan-Pacific (130Hz):** At this frequency setting, the operator will see a decrease in torque values displayed as the speed of the power tool is increased. The 130Hz frequency filter in conjunction with software averaging cuts off signals above 130Hz, which will result in slightly lower torque values being displayed with increased RPM.

**2. Mountz (170Hz):** At this frequency setting, the operator will see limited or no change to the torque values being displayed as the speed of a power tool is increased. The 170Hz frequency filter in conjunction with software averaging cuts off signals above 170Hz, which will result in little or no change to torque values being displayed with increased RPM.

**3. ISO (500Hz):** At this frequency setting, the operator will see an increase in torque values displayed as the speed of the power tool is increased. The 500Hz frequency filter in conjunction with software averaging cuts off signals above 500Hz, which will result in higher torque values being displayed with increased RPM. The 500Hz frequency setting is offered for customers seeking to test power tools in accordance the ISO standard ISO 5393.

## External Connections

On the left side, there are three slots for external connections.

### External Power Supply

Plug the provided transformer to charge the internal batteries in the unit.

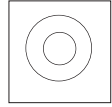

### RS 232 Connection:

The RS 232 can be used for printing or downloading torque values into a computer or used with an external PC to calibrate the unit.

Rate: 19,200 BPS

Output Format: 8 bits fixed, 1 stop bit, no parity.



### Pin-Out

The following diagram and Table define the pins of the I/O connectors for the EZ-TorQ Torque Tester.

Pin Numbers  
6.....

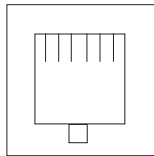

RS 232

RS 232 Connector

Pin	Signal
1	Not used
2	RXD
3	TXD
4	Not Used
5	Ground
6	Not Used

### Analog Output

Connector provided for those that wish to monitor the amplified analog signal before the analog to digital conversion.



## POWER TOOL TESTING

The run down adapters (RDA) are designed to provide consistent and reliable torque readings for use with power driven torque control tools. The RDA's reduce the impact and irregular peaks that cause poor repeatability. Each RDA has an effective torque range and will supply repeatable torque data within that range if used correctly.

Always use a quality joint rate simulator (run down adapter) when testing power tools in a simulated application. Use the peak mode. The Peak mode is designed to meet the demanding frequency requirements for testing dynamic torque applications.

### Using Run Down Adapters

The EZ-TorQ includes a 1/4 Female Hex Square Drive Adapter which is used for testing hand tools. It also includes a Run Down Adapter

#### Operation

1. The run down adapter is placed in-line between the tool drive and transducer of the torque tester.
2. The torque tester should be properly secured on a solid surface or a test bench.
3. Before each test run, the Input drive run down adapter (RDA) should be completely backed-up. (Unless using Mountz AURA run down adapter)
4. The RDA is designed to run in clockwise direction only.
5. Apply torque until RDA is run down completely. Then note or save reading with the torque tester.

## Installation of the "EZ-TorQ II Interface Software"

The interface program allows the operator to conduct Tool Tests, Data logging and Sensor Calibration.

1) Insert the CD into the PC and the EZ-TorQ II Interface Program splash screen will appear. Click on the "Install EZ-TorQ II Program"

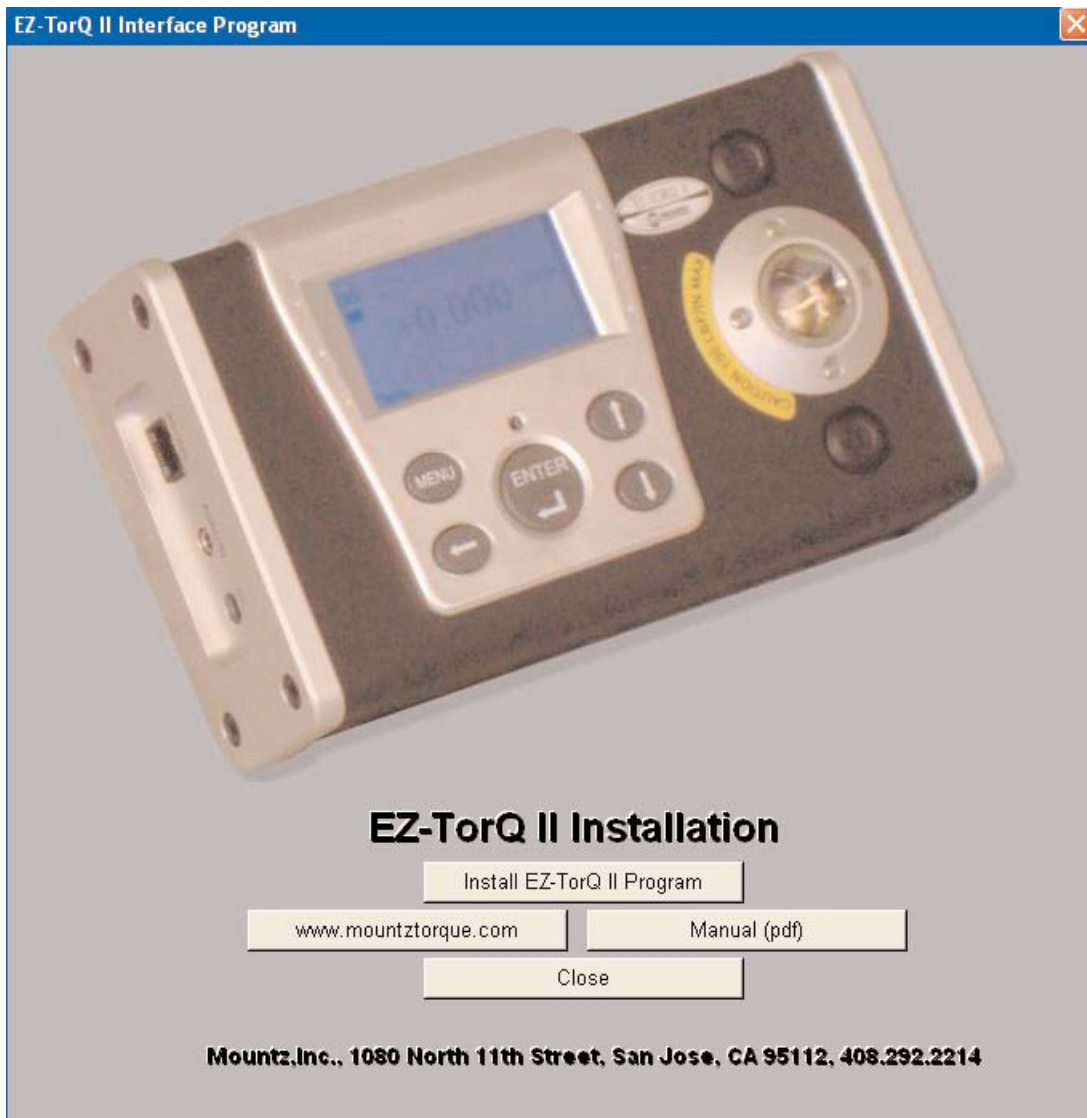

- 3) Click Install.
- 4) After the installation is successful click Finish.

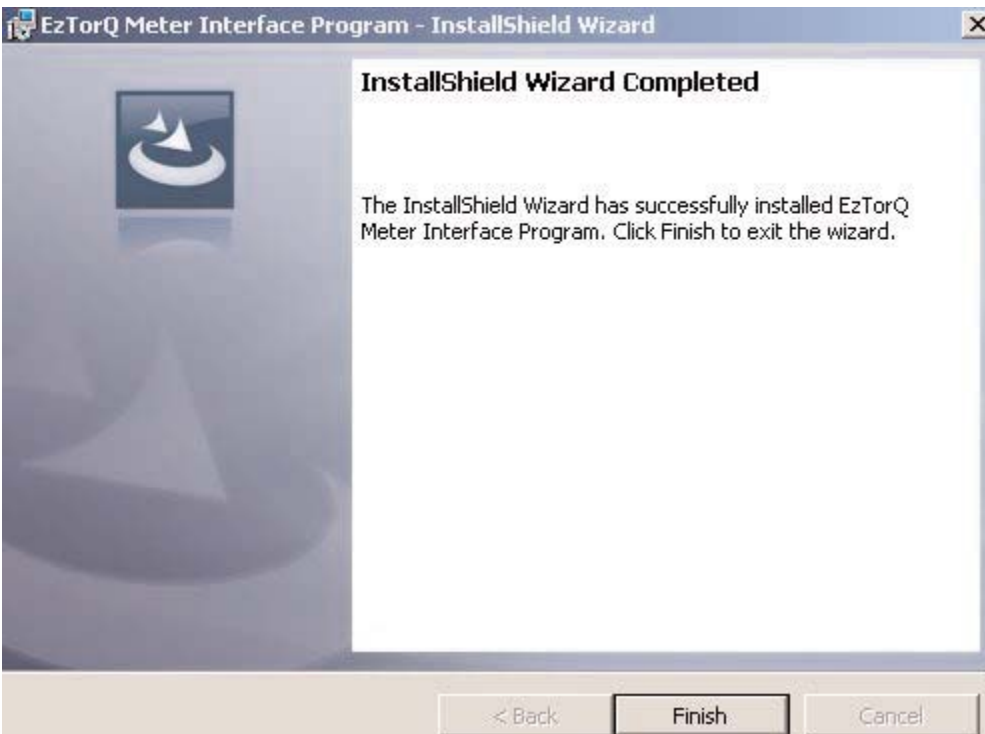
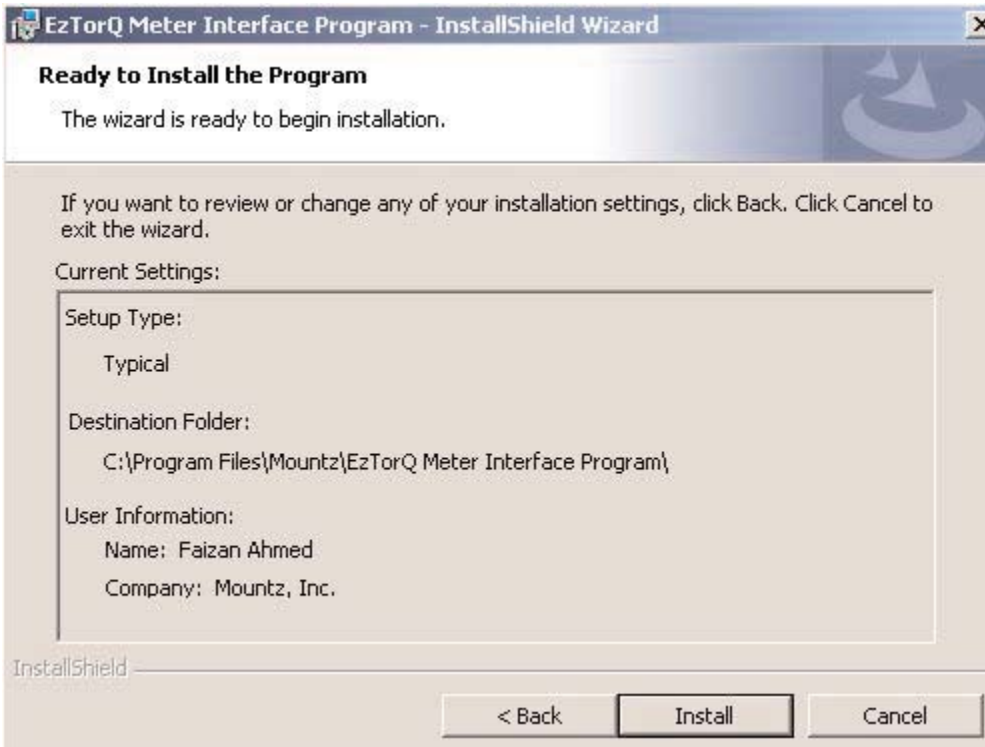

- 5) After installation of the EZ-TorQ Interface Program, turn on the unit and connect it to a PC through the RS-232 port.
- 6) A Green light will show on the Interface Program indicating that the software was installed and the unit is connected properly.

## COM Port Selection

The EZ-TorQ Interface Program contains a com port selection tab which allows for selection of a specific com port. The default setting is Com 1. Go to File Menu, select Com Port.

If using a USB connection, Toggle through the com port selections and click ok on the available selections until the On-Line indicator turns Green. The EZ-TorQ meter must be turned on to establish a connection. The COM port setting can also be verified by checking port assignments via device manager.

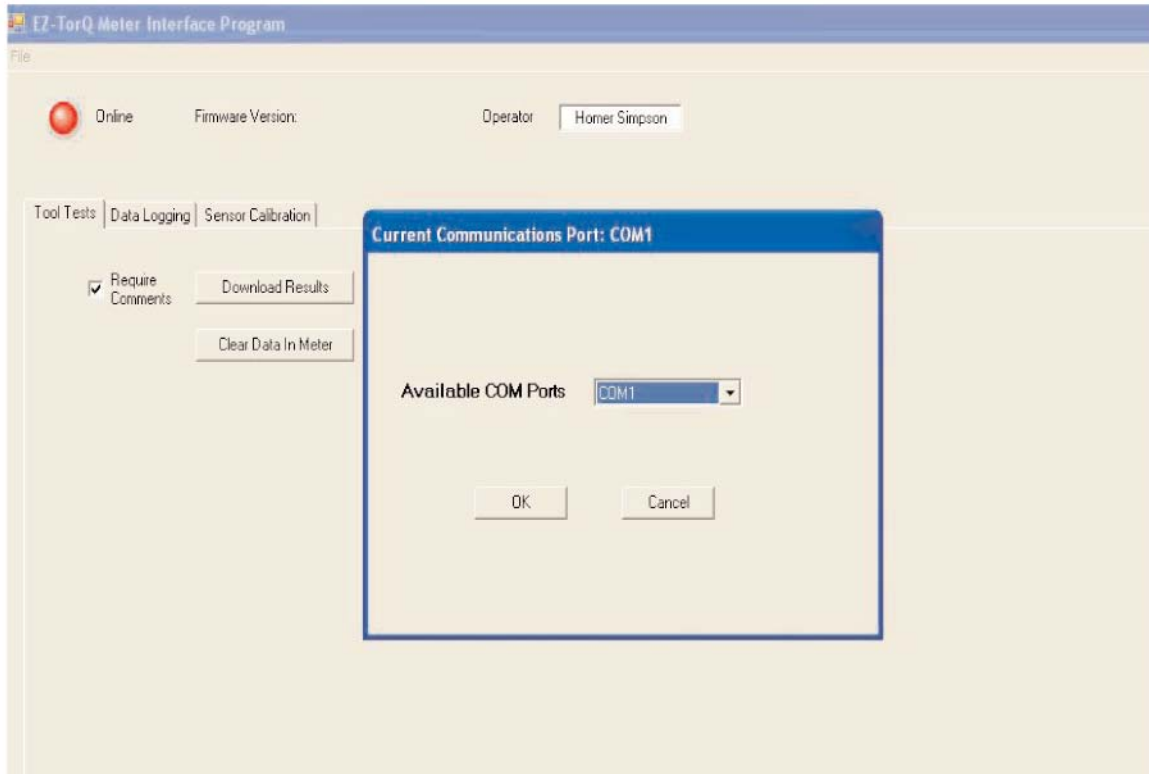

## Quick Test Downloading

The EZ-TorQ Meter Interface software can be used to download the results of the Quick test data stored in the meter. The test data stored in the meter can be deleted using this program or deleted using the menu in the meter. If you desire to add comments to the download, check the "Require Comments" check box and you will be provided with a window to add comments to the downloaded results.

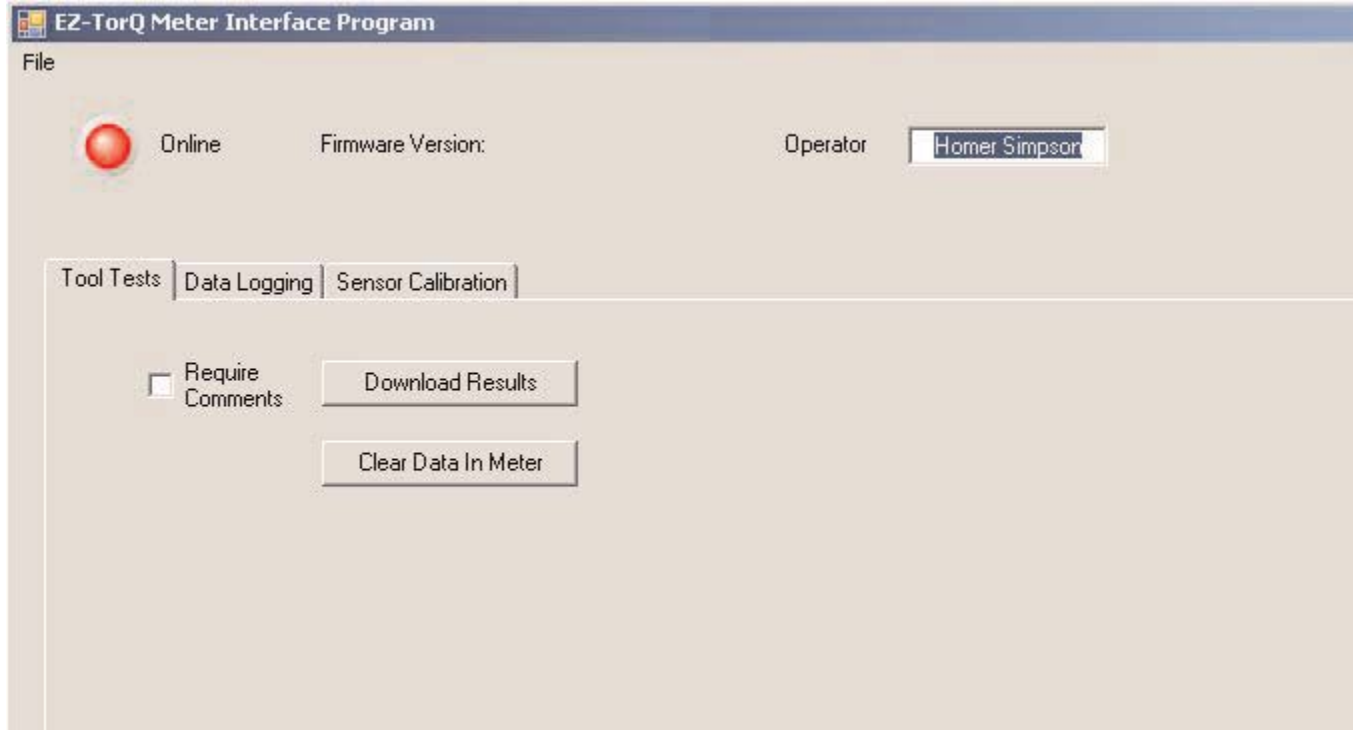

- 1) Download Results - Retrieves the results of a QuickTest after it has been run. It will offer a chance to add further notes to the test at this point. The results will save in the PC in a location of your choice in a folder under the name entered in the "Operator" field in the upper portion of EZ-TorQ Meter Interface software. The results are stored in a .csv file which can be opened in Excel or using a text editor program, such as Notepad. The file name will be the QuickTest number followed by the date and the time at which the test was started.
- 2) Clear Data in Meter - Clears the test data for the QuickTest in the EZ-TorQ II meter. The operator will be asked for confirmation before the action takes place.

# Data Logging

The Data Logging tab of the EZ-TorQ Meter Interface software provides a feature to graph torque vs time in real time. The Data Logging tab also provides a "Real-time" feature that allows the capture of meter readings into an Excel Spreadsheet.

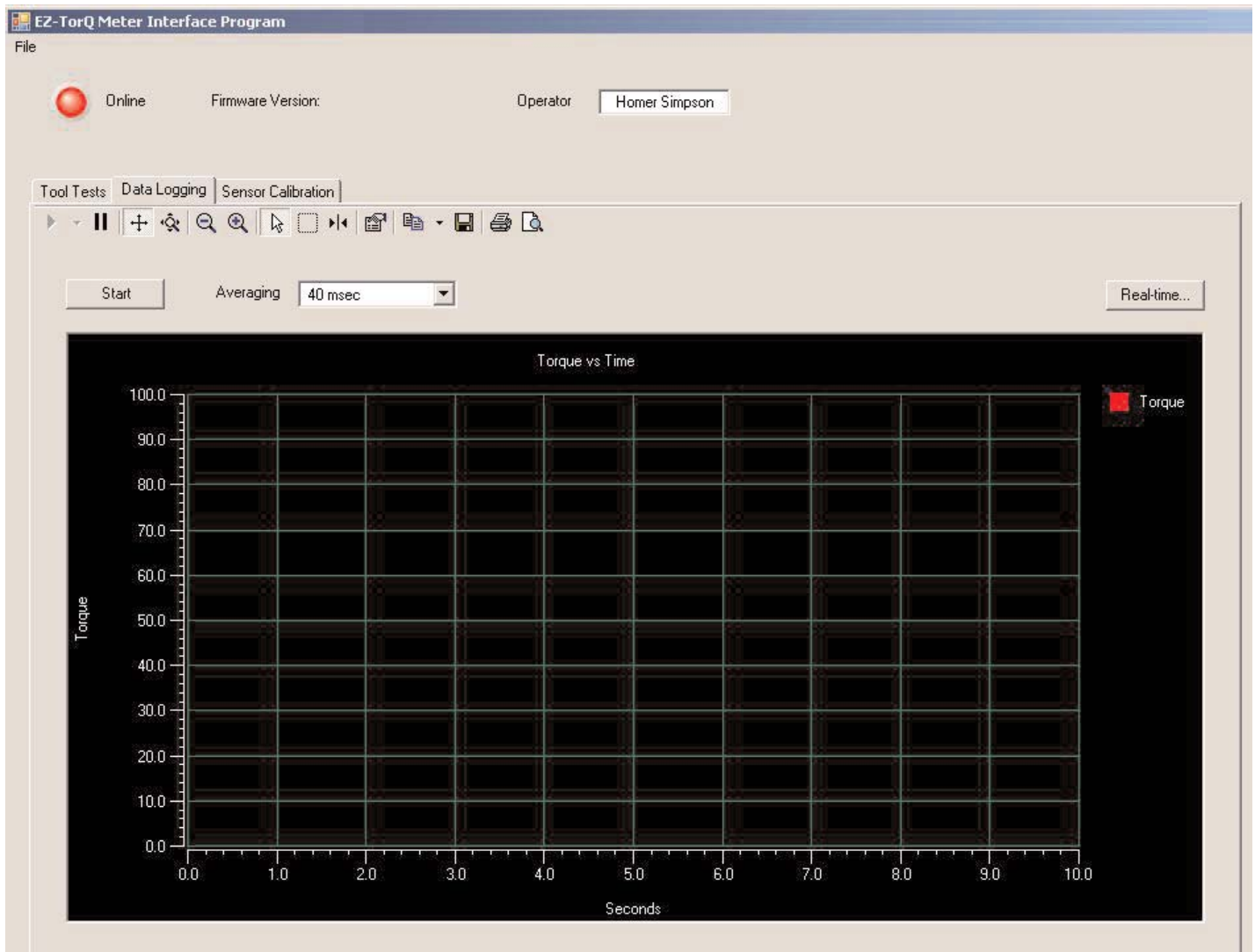

- 1) Graph: The real time torque vs. time graph can be accessed by clicking on the Data logging tab, and then clicking on the Start button on the top left side of the screen. After torque has been applied and the desired graph has been obtained, click the Stop button to stop the collection of readings. There are different features available at the top of the Start button that can be utilized for the graph.

2) Real-time: The Real-Time button on the upper right side of the Data Logging screen allows a user to connect the EZ-TorQ II Meter to a PC and get readings sent to the PC, in Real-Time, which can be printed to a printer or saved as an Excel Spread Sheet. The screen reading is sent from the Meter when Auto clear takes place or when Enter is pressed if the meter is in Manual Clear mode.

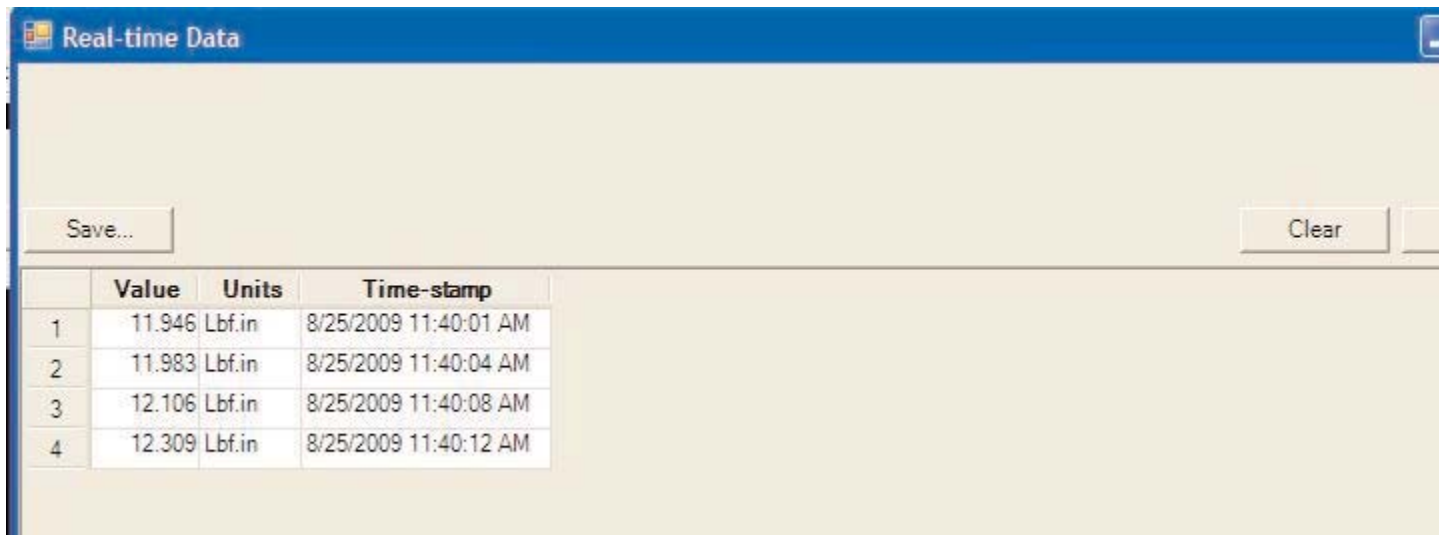

## Bootloader

This program is used to update the code in the EZ-TorQ II unit. This program does not automatically install as the Interface program does when CD is inserted into the PC. Insert the CD into the PC. Locate the Bootloader.exe file and click on it, a small window will pop up as shown below.

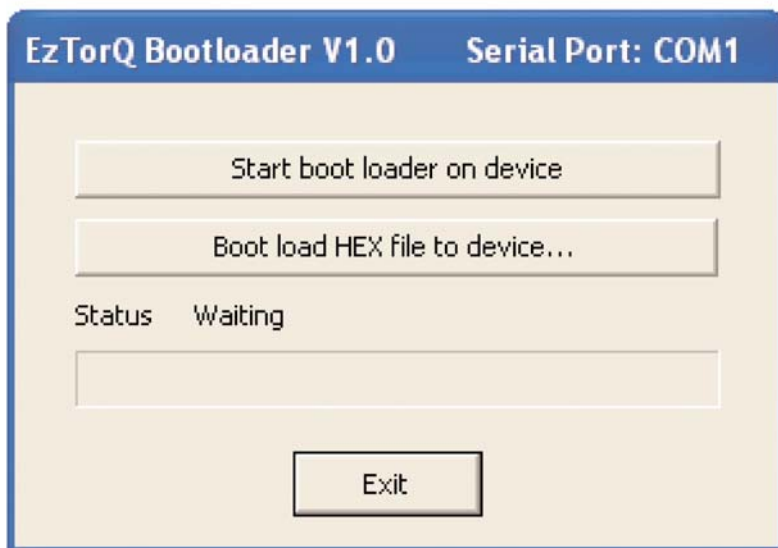

The EZ-TorQ II is supplied with RS-232 cable adapter and USB serial converter adapter. Connect the RS-232 cable to the torque tester and the computer. Turn on the EZ-TorQ II unit. Click the button "Start boot loader on device" and the EZ-TorQ II screen will indicate the EZ-TorQ II is in bootloader mode.

To update the firmware click the "Boot load HEX file to device" button, and locate the hex file on the computer. The

process will take about 6 minutes. The status will be shown in the EZ-TorQ Bootloader window as the process takes place.

In some cases when a computer does not have an RS-232 connector and the USB serial converter adapter is used, the serial port where the connection is received might come in at a port different than COM1. In this situation if the user wants to update the firmware through the Bootloader program, the user needs to perform the following procedure:

- 1) Right-Click the Bootloader.exe file and click on Create Shortcut.
- 2) Once the shortcut is created, right click on "Shortcut to BootLoader.exe" file and click on Properties.
- 3) Under the Shortcut menu locate the Target address box.
- 4) In the Target address box the user will see the address of the shortcut file as shown in the example below:  
"C:\Documents and Settings\Administrator\Desktop\EzTorQ II- ALL FILES\Latest EzTorQ II CD Jan 4th 2010\BootLoader.exe"
- 5) Right after BootLoader.exe" add a space and forward slash followed by the ComPort the connection comes in at as shown in the example below: "C:\.....exe" /com6

## BATTERY OPERATION

The EZ-TorQ II Meter is powered using Li-Ion batteries for long battery life. The battery pack should last up to 40 hours with normal use and maximum charge. The battery icon is always on the display. It is filled in completely when fully charged and shows white space as the battery depletes.

When the battery strength appears low, the unit should be connected to the external AC adapter to charge the batteries. The torque readings may become inaccurate when the unit is used with a low battery. Charging time is 4 hours minimum, but the unit may be used with charging.

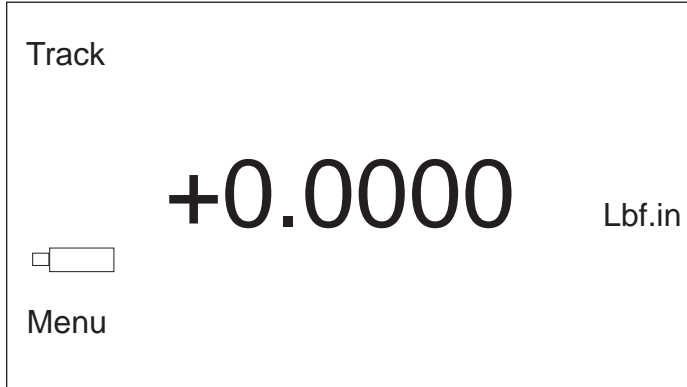

### Universal Charger/ Adapter

The unit is supplied with a Universal Charger/ Adapter with auto volt feature -100-240 V, and the user does not have to physically change the voltage setting.

Item # 770300

## Accessories

Model	Item #
Universal Charger (for EZ-TorQ)	770300
Case (for EZ-TorQ)	600729
Battery Pack (for EZ-TorQ)	603107
Brush Cap	14-501830
RS232 Cable	773064
Serial to USB Adapter	773069
1/4 F/Hex Sq. Dr Adapter (17mm F/Hex)	600727
Square Dr. Adapter (1/4 Sq. Dr x 1/4 Hex x 2" Oal)	120143
Spring RDA10i	070600
Spring RDA50i	070605
Spring RDA100i	070610
Spring RDA150i	070615

### Service

Mountz Inc. features an experienced calibration and repair staff. Our trained technicians can calibrate and repair most any tool. Mountz provides rapid service with quality that you can trust as we offer three state-of-the-art calibration lab and repair facilities that can calibrate up to 20,000 lbf.ft.

With over 45 years of experience, Mountz's in-depth knowledge of torque is reflected in our tool's craftsmanship and our ability to provide solutions to both common and uncommon torque applications. We perform calibrations in accordance with ANSI/NCSL-Z540. Mountz is dedicated solely to the manufacturing, marketing and servicing of high quality torque tools.

### Tool Service & Repair Capability

Torque Wrenches: Click, Dial, Beam, Cam-Over & Break-Over

Torque Screwdrivers: Dial, Micrometer, Preset & Adjustable

Torque Analyzers/Sensors: All brands

Electric Screwdrivers: All brands

Air Tools: All brands

Impact Wrenches, Drills, Pulse Tools, Grinders, Percussive Tools,  
Air Screwdrivers, Nutrunners, DC Controlled Nutrunners

Torque Multipliers: All brands

### Mountz Service Locations

#### *Eastern Service Center*

19051 Underwood Rd.  
Foley, AL 36535  
Phone: (251) 943-4125  
Fax: (251) 943-4979

#### *Western Service Center*

1080 N.11th Street  
San Jose, CA 95112  
Phone: (408) 292-2214  
Fax: (408) 292-2733

#### *Mexico Service Center*

Mountz Mexico SA de CV Chihuahua  
Av. Cristobal Colon #15343  
Col. Paseos de Chihuahua  
Chihuahua, Chih. Mexico CP 31125  
Phone: (614) 481-0023  
Fax: (614) 481-0053

[www.mountztorque.com](http://www.mountztorque.com)  
[sales@mountztorque.com](mailto:sales@mountztorque.com)

Download a "Service Form" and include a copy  
when you send the tools in to be serviced.

Looking for fasteners?  
[www.mrmetric.com](http://www.mrmetric.com)

