

MMTB (Miniature Break-Over Wrench) Operating Instructions

Rev 2.0 (10/17/2011)

Ref. Item # 500295

MMTB “Break-Over” Wrenches

These small production wrenches ‘break-over’ once reaching preset torque setting. Compact and well balanced, these wrenches have a fixed head attached to it and are ideally suited for low torque settings or applications with tight space restrictions.

Calibrating Torque Wrenches

To calibrate torque wrenches either use a torque tester or torque sensor within the range of the torque wrench. For break-over torque wrenches calibrate torque in “Peak” mode with a digital torque tester or torque sensor. Make sure to apply the torque slowly and smoothly at the “Load Point Line” near end of the handle.

1. Select a torque tester or torque sensor that covers the torque range of the MMTB wrench. Connect wrench to the torque analyzer or transducer using the appropriate adapters as needed (not supplied).
2. Apply torque clockwise slowly until wrench ‘breaks-over’ and note reading.
3. Adjust wrench to required torque setting as described below.
4. Test and repeat adjustment as necessary to obtain desired value.
5. Recalibrate torque wrench at prescribed intervals.

Adjusting Torque Setting

1. Remove set screw from the handle with 10/32 Hex Key.
2. Insert 10/32 hex key into adjusting screw and turn clockwise to increase torque and counter clockwise to decrease torque. Do not adjust torque above or below the recommended torque ranges. Tighten set screw back on.

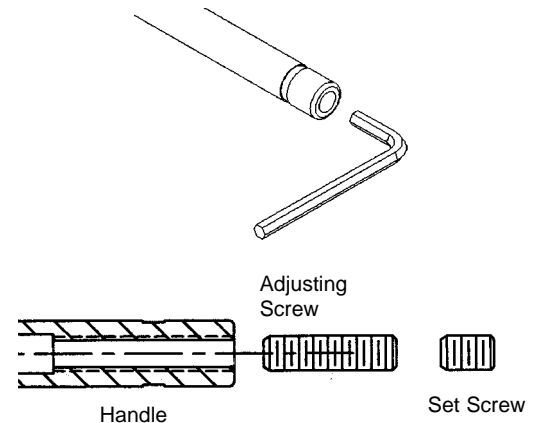

Applying Torque

1. Toward the end of the wrench is the “Load Point Line.” Grab handle at that “Load Point” end to apply torque. (If you grab handle closer toward head, then you will apply more torque than what the wrench is set for. The wrench is a length dependent tool).
2. Tighten nut or bolt by applying a steady even pull. Wrench should be kept at 90 degrees to axis of bolt during tightening. When pre-set torque is reached, the wrench will ‘break.’ Stop pulling once 45° break angle is achieved.
2. Reset the wrench for the next application.
3. With its unique design, it’s impossible to over tighten beyond the preset load.

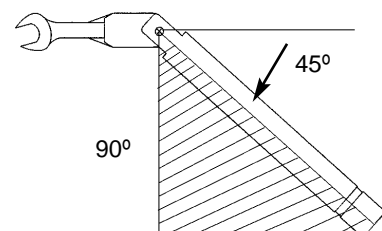
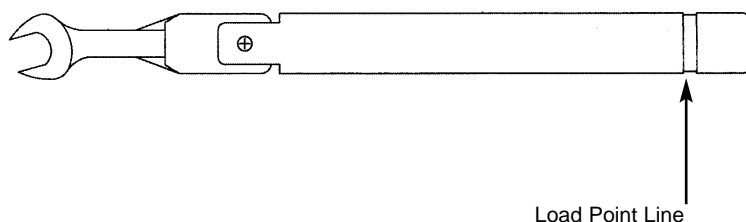



MMTB (Miniature Break-Over Wrench) Operating Instructions

Rev 2.0 (10/17/2011)

Ref. Item # 500295

Mountz Calibration & Repair Services

Mountz Inc. features an experienced calibration and repair staff. Our trained technicians can calibrate and repair most any tool. Mountz provides rapid service with quality that you can trust as we offer three state-of-the-art calibration lab and repair facilities that can calibrate up to 20,000 lbf.ft.

With over 45 years of experience, Mountz's in-depth knowledge of torque is reflected in our tool's craftsmanship and our ability to provide solutions to both common and uncommon torque applications. We perform calibrations in accordance with ANSI/NCSL-Z540. Mountz is dedicated solely to the manufacturing, marketing and servicing of high quality torque tools.

Mountz is an ISO 9001 certified and ISO 17025 accredited company.

Tool Service & Repair Capability

- Torque Wrench Calibration: Click Wrench, Dial Torque Wrench, Beam Wrench, Cam-Over & Break-Over Wrench
- Torque Screwdrivers: Dial, Micrometer, Preset & Adjustable
- Torque Analyzers/Sensors: All brands
- Electric Screwdrivers: All brands
- Air Tools: All brands
Impact Wrenches, Drills, Pulse Tools, Grinders, Percussive Tools, Air Screwdrivers, Nutrunners, DC Controlled Nutrunners
- Torque Multipliers: All brands

Mountz Torque Testers and Calibration Equipment

Torque tools go out of calibration with use. Calibrating a torque tool is a fine-tuning process of bringing the tool back within its tolerance. Torque testers can also be used for quick tools tests on the line or in the lab to determine whether torque tools are holding a given setting.

A regular torque tool calibration and re-calibration guarantees the operator repeatable accuracy and adherence to international standards. Torque testing also ensures torque equipment is operating to peak performance and can highlight potential tooling problems before they arise perhaps due to tool wear or broken components.

Controlling torque is essential for companies to ensure their product's quality, safety and reliability isn't compromised. The failure of a three-cent fastener that isn't properly tightened can lead to catastrophic or latent failures. Fasteners that are insufficiently torqued can vibrate loose and excessive torque can strip threaded fasteners. Using a quality torque tool has become increasingly important for many companies to ensure that proper torque is being applied and maintains gauge requirements associated with the ISO 9001 Quality Standard. Look for the Mountz hexagon logo - it's a stamp for quality tools, service and knowledge in the field of torque control.

Mountz Service Locations

Eastern Service Center

19051 Underwood Rd.
Foley, AL 36535
Phone: (251) 943-4125
Fax: (251) 943-4979

Western Service Center

1080 N.11th Street
San Jose, CA 95112
Phone: (408) 292-2214
Fax: (408) 292-2733

Mexico Service Center

Mountz Mexico SA de CV Chihuahua
Av. Cristobal Colon #15343
Col. Paseos de Chihuahua
Chihuahua, Chih. Mexico CP 31125
Phone: (614) 481-0023
Fax: (614) 481-0053

www.mountztorque.com

sales@mountztorque.com

Download a "Service Form" and include a copy when you send the tools in to be serviced.

Looking for fasteners?

www.mrmetric.com

