

# MTM 15 Operating Manual

Rev. 1.0

## Tightening or loosening using a torque wrench

**1a.** Insert the reaction lever into the multiplier head. The pin on the multiplier head should fit securely in the hole on the reaction lever. **1b.** Or, insert the right angle reaction bar and reaction base into the multiplier head. The pin on the multiplier head should fit securely in the hole on the reaction bar.

**2.** Starting from nut, insert: socket, multiplier and torque wrench.

**3.** The reaction lever must be positioned against an object so it cannot move. The multiplier can work both clockwise and counterclockwise. Pay attention that the reaction lever is fixed in the correct way.

**4.** Using the torque wrench, apply continuous force until the application is tightened or loosened satisfactorily.

**Note:** The torque output of the multiplier is based on a torque multiplication ratio of the torque applied from the torque wrench. The torque multiplication for MTM-15 is 6.5:1

**5.** After you have finished tightening, the torque wrench must be released slowly to ease the multiplier accumulated energy.

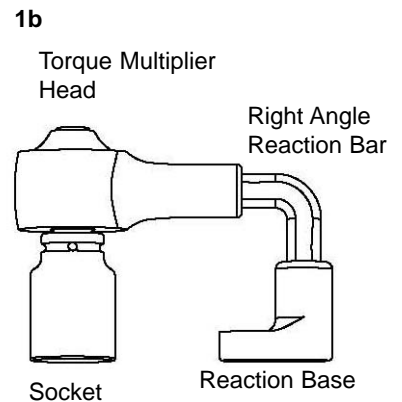
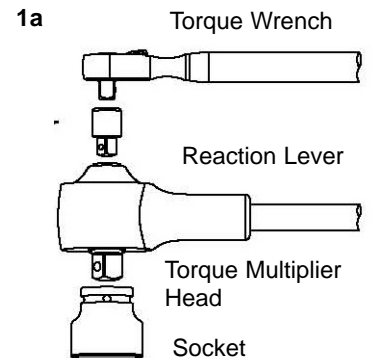

## Break-Away Adapter for MTM-15

**1.** The MTM-15 case set includes a break-away safety adapter.

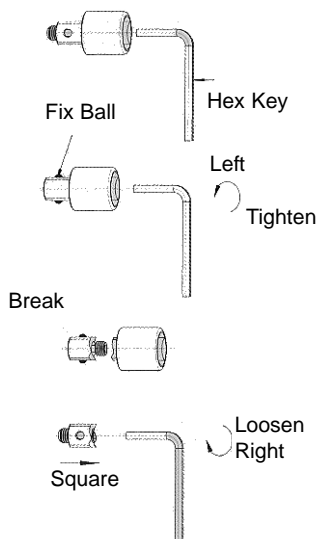

The break-away safety adapter is inserted into the square opening of the torque multiplier.

Use the hex key by turning it left to tighten the fixed balls and firmly connect the break-away safety adapter to the torque multiplier.

In case of an overload, the break-away safety adapter will break and let the user know an overload has occurred.

Use the hex key and turn it right to remove the parts of the break-away safety adapter that still remain in the torque multiplier.



408.292.2214  
Fax: 408-292-2733

sales@etorque.com

www.etorque.com



# MTM 27 Operating Manual

Rev. 1.0

## Tightening or loosening using a torque wrench

**1a.** Insert the reaction lever into the multiplier head. The pin on the multiplier head should fit securely in the hole on the reaction lever. **1b.** Or, insert the right angle reaction bar and reaction base into the multiplier head. The pin on the multiplier head should fit securely in the hole on the reaction bar.

**2.** Starting from nut, insert: socket, multiplier and torque wrench.

**3.** The reaction lever must be positioned against an object so it cannot move. The multiplier can work both clockwise and counterclockwise. Pay attention that the reaction lever is fixed in the correct way.

**4.** Using the torque wrench, apply continuous force until the application is tightened or loosened satisfactorily.

**Note:** The torque output of the multiplier is based on a torque multiplication ratio of the torque applied from the torque wrench. The torque multiplication for the MTM-27 is 3.3:1

**5.** After you have finished tightening, the torque wrench must be released slowly to ease the multiplier accumulated energy.

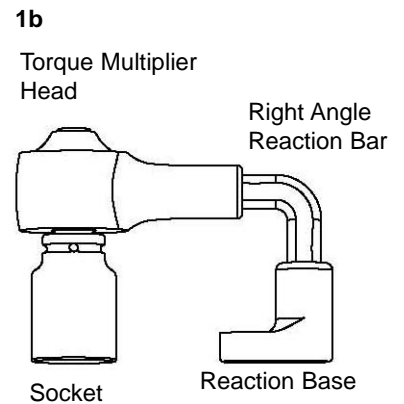
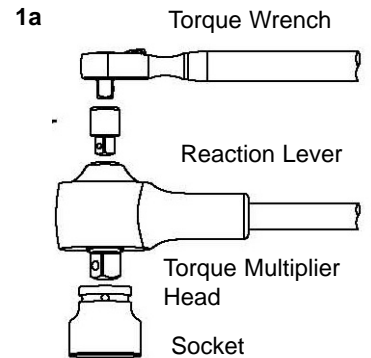

## Mountz Calibration & Repair Services

With over 40 years of experience, Mountz features an experienced calibration and repair staff that delivers rapid service and provides quality that you can trust. Mountz features a new state-of-the-art calibration lab and a repair facility. The Calibration Lab can calibrate up to 20,000 lbf.ft. Our certified technicians can calibrate & repair most any tool and our calibration standards are traceable to NIST (National Institute of Standards and Technology). Mountz factory service provides current upgrades for all digital torque analyzers at time of service.

## Mountz Service Centers

Mountz, Inc.  
19051 Underwood Rd  
Foley, AL 36535  
Phone: (251) 943-4125  
Fax: (251) 943-4979

Mountz, Inc.  
1080 N. 11th St  
San Jose, CA 95112  
Phone: (408) 292-2214  
Fax: (251) 292-2733



408.292.2214  
Fax: 408-292-2733

sales@etorque.com

www.etorque.com

