

# MTP10 Dial Torque Analyzer Operation & Calibration Instructions

Rev 2.0 (5/11/2011)

## MTP Dial Torque Analyzer

This torque analyzer is designed only for hand torque wrenches and screwdrivers. This torque tester is not suitable for power tools.

## Mounting MTP Dial Torque Analyzer

The Dial Torque Analyzer needs to be mounted securely on a level surface before operating. Immobilizing the torque tester is critical for the safety of the operator as well as for the accuracy of torque measurements during operation. A loose torque tester during utilization can impact the validity of torque readings.

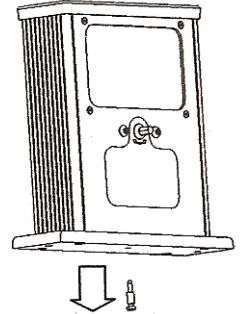

## Operating MTP 10 Torque Analyzer

1. The MTP 10 features 1/4" male hex drive. Attach an adapter into the drive (if needed).
2. Insert hand tool onto the drive and slowly apply torque clockwise or counterclockwise and note reading when screwdriver reaches maximum torque.
3. Adjust the torque setting of the hand tool (if needed).
4. Re-check torque setting of the hand tool.

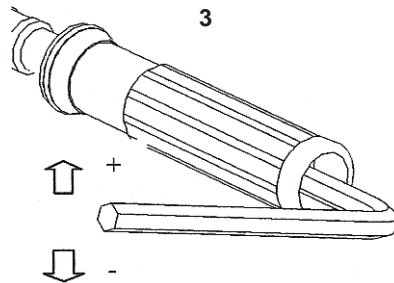
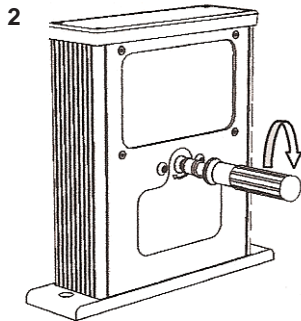

## Testing & Servicing

In order to maintain accuracy, it is crucial that torque control measuring equipment be calibrated regularly.

We recommend a general once a year calibration interval. However, it is the user's organization that must determine suitable intervals based upon equipment performance, application, degree of usage and management objectives.

For calibration, re-adjustment or repairs, please send the tool to one of our 3 service locations.

# MTP10 Dial Torque Analyzer Operation & Calibration Instructions

Rev 2.0 (5/11/2011)

## Calibration Procedures

1. The accuracy of the dial torque analyzer should only be verified using an appropriate Calibration Equipment and Weight Set traceable to national standards.
2. Mount the Dial Torque Analyzer on a suitable, level bench surface.
3. Load the analyzer using the Calibration Equipment and Weight Set to give a torque equivalent to 20% of the full scale range and compare with indication on the analyzer dial.
4. Check the Dial Analyzer at all major graduations and adjust, if need, as described below until all values are within +/- 2% of reading or 1 graduation, whichever is greater.

## Adjustments for MTP model

If the MTP model doesn't indicate the true torque applied within the stated tolerance, then calibration adjustments are required and performed as described.

1. Remove rear cover (not shown).
2. Check position of dial indicator for zero with out any torque / weight applied.
3. Apply the determined loads at the positions
4. If adjustment is required the main weight requires adjusting. While viewing the unit from the back, release the main weight retaining screw. If the value on the dial needs to be decreased then move the weight upwards towards the pivot point. Then tighten the retaining screw. If the value on the dial needs to be increased then move the weight downwards away from the pivot point. Then tighten the retaining screw.
5. Repeat step 3 to ensure the readings match the torque/weight applied.
6. Replace rear cover (not shown).

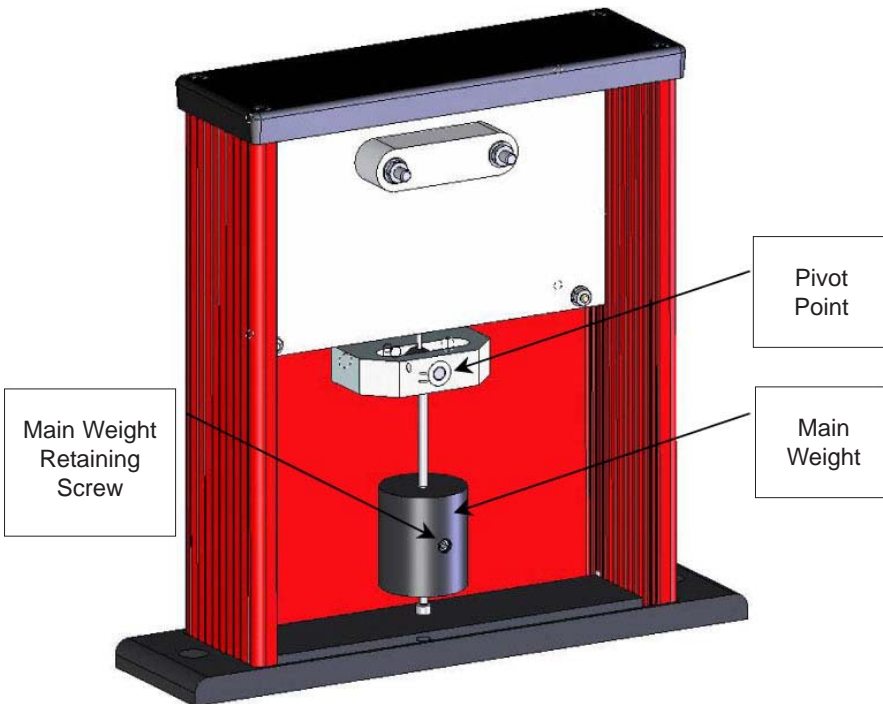

## Mountz Service Locations

### Eastern Service Center

19051 Underwood Rd.  
Foley, AL 36535  
Phone: (251) 943-4125  
Fax: (251) 943-4979

### Western Service Center

1080 N.11th Street  
San Jose, CA 95112  
Phone: (408) 292-2214  
Fax: (408) 292-2733

### Mexico Service Center

Mountz Mexico SA de CV Chihuahua  
Av. Cristobal Colon #15343  
Col. Paseos de Chihuahua  
Chihuahua, Chih. Mexico CP 31125  
Phone: (614) 481-0023  
Fax: (614) 481-0053

[www.mountztorque.com](http://www.mountztorque.com)  
[sales@mountztorque.com](mailto:sales@mountztorque.com)

Download a "Service Form" and include a copy when you send the tools in to be serviced.

Looking for fasteners?  
[www.mrmetric.com](http://www.mrmetric.com)

