

# MTS Dial Torque Analyzer Operation & Calibration Instructions

Rev 2.0 (5/11/2011)

## MTS Dial Torque Analyzer

This torque analyzer is designed only for hand torque wrenches and screwdrivers. This torque tester is not suitable for power tools.

## Mounting MTS Dial Torque Analyzer

The Dial Torque Analyzer needs to be mounted securely on a level surface before operating. Immobilizing the torque tester is critical for the safety of the operator as well as for the accuracy of torque measurements during operation. A loose torque tester during utilization can impact the validity of torque readings.

## MTS Models are supplied with a Reversible Adapters

Reversible Adapter  
(1/4 M/Hex. & 1/4 F/Sq.)

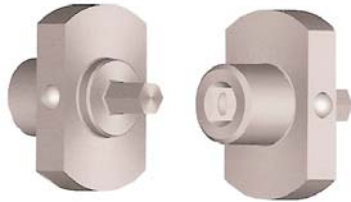

For models:  
MTS 35  
MTS 130  
MTS 400

Reversible Adapter  
(1/4 F/Sq. & 3/8 F/Sq.)



For models:  
MTS 1200  
MTS 2500

## Operating MTS Torque Analyzer

1. Attach appropriate adapter into the drive opening of the MTS.
2. Set the Min and Max torque range.
3. Insert hand tool onto the drive and slowly apply torque clockwise and note reading when screwdriver reaches maximum torque. (Note - MTS model can only be used in clockwise direction).
4. Adjust the torque setting of the hand tool (if needed). The Spindle Lock eliminates the need to remove tool from the drive during torque adjustment. First, pull out the Spindle Lock to lock the drive. Secondly, adjust the torque setting of hand tool.
5. Push the Spindle Lock back in to unlock the drive. Re-check torque setting of the hand tool.

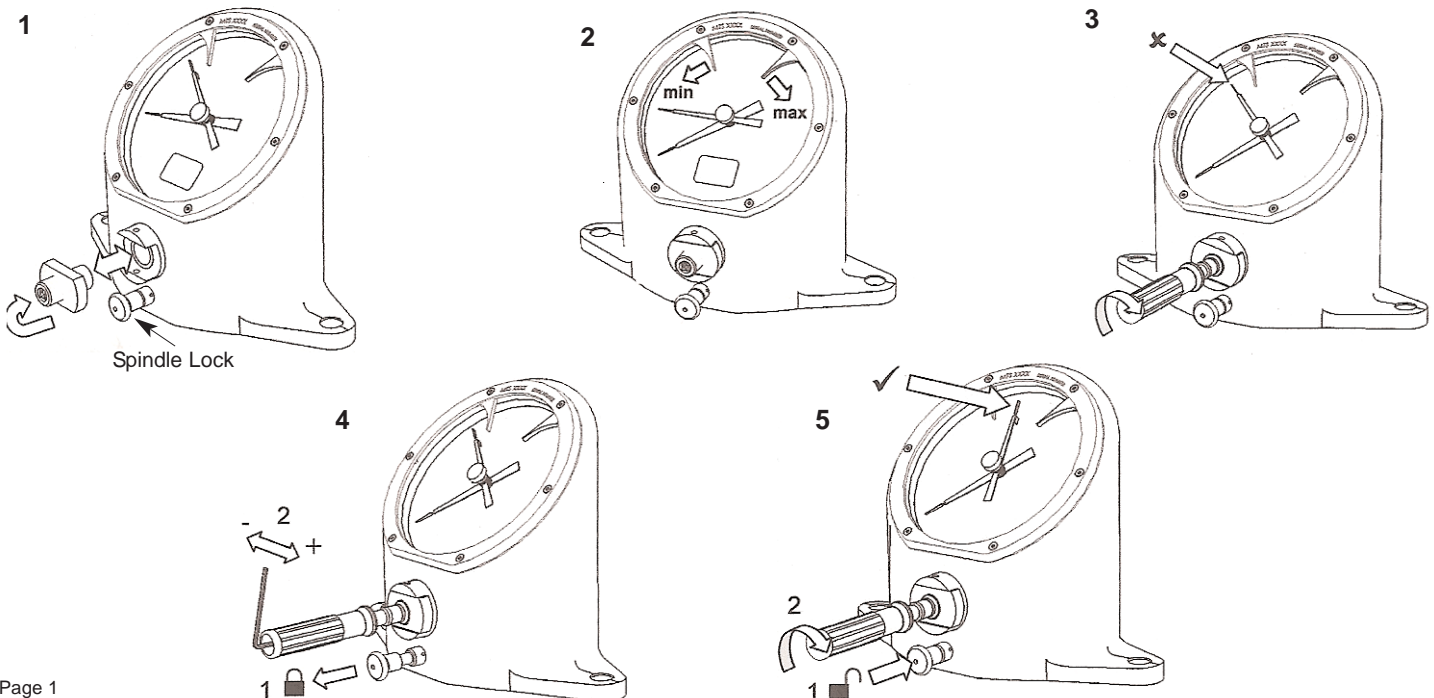

## MTS Dial Torque Analyzer Operation & Calibration Instructions

Rev 2.0 (5/11/2011)

### Calibration Procedures

1. The accuracy of the dial torque analyzer should only be verified using an appropriate Calibration Arm or Wheel and Weight Set traceable to national standards.
2. Mount the Dial Torque Analyzer on a suitable, level bench surface.
3. Load the analyzer using the Arm or Wheel and Weight Set to give a torque equivalent to 20% of the full scale range and compare with indication on the analyzer dial. **Do not use the memory pointer during verification.**
4. Check the Dial Analyzer at all major graduations and adjust, if need, as described below until all values are within +/- 2% of reading or 1 graduation, whichever is greater.

### Adjustments for MTS models

If the MTS model doesn't indicate the true torque applied within the stated tolerance, then calibration adjustments are required and performed as described.

1. Remove rear cover (not shown).
2. Check position of dial indicator for zero with out any torque / weight applied. If adjustment is required then use the main adjustment screw to align the indicator with the zero position.
3. Apply the maximum load to the unit, to establish if adjustment is required to align the indicator with the top reading. Use the main adjustment screw as required.
4. Apply the determined loads at the positions in the MTS calibration weight, see page 3. This should be completed for each position.
5. If adjustment is required then turn the spring pivots, both spring pivots need to be turned together and by the same amount. While viewing the unit from the back, there is a reference dot on the spring pivots. If the value on the dial needs to be decreased then turn the spring pivots clockwise (reference dot to the left). If the value on the dial needs to be increased then turn the spring pivots anti-clockwise (reference dot to the right).
6. Repeat step 4 to ensure the readings match the torque/weight applied.
7. Replace rear cover (not shown).

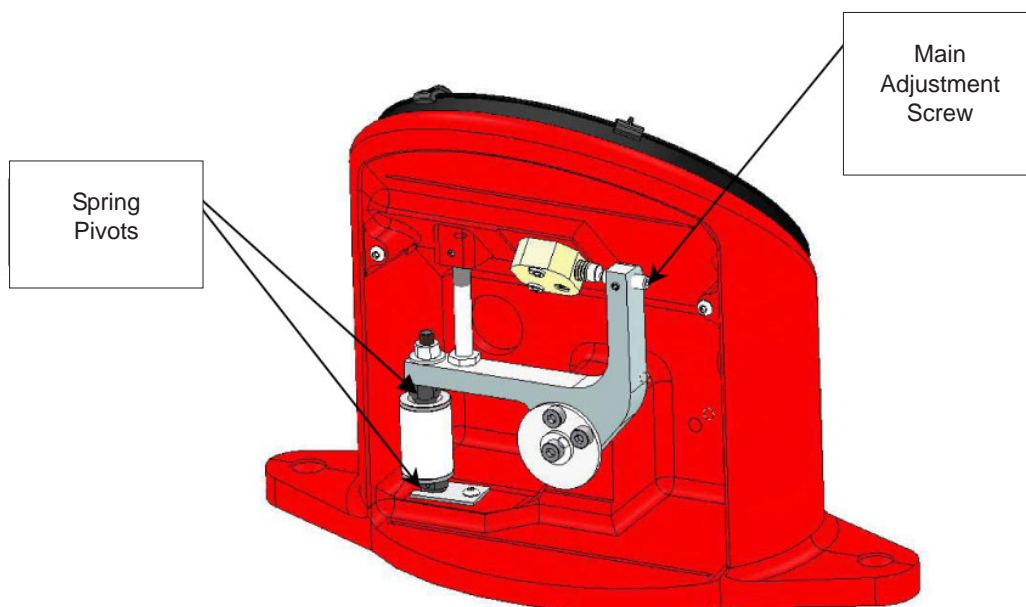

# MTS Dial Torque Analyzer Operation & Calibration Instructions

Rev 2.0 (5/11/2011)

## Calibration Weights for MTS

Use Calibration Wheel

MTS35		MTS 130	
Cal point	Weight (Nm)	Cal point	Weight (Nm)
0.5	0.5	20	2
1	1	40	4
1.5	1.5	60	6
2	2	80	8
2.5	2.5	100	10
3	3	120	12

## Calibration Equipment for MTS

Use Calibration Arm

MT400		MTS 1200	
Cal point	Weight (Nm)	Cal point	Weight (Nm)
0.5	2	1	4
1	4	2	8
1.5	6	3	12
2	8	4	16
2.5	10	5	20
3	12	6	24
3.5	14	7	28
4	16	8	32
		9	36
		10	40
		11	44
		12	48

MTS 2500	
Cal point	Weight (Nm)
5	20
10	40
15	60
20	80
25	100

## Mountz Service Locations

### Eastern Service Center

19051 Underwood Rd.  
Foley, AL 36535  
Phone: (251) 943-4125  
Fax: (251) 943-4979

### Western Service Center

1080 N.11th Street  
San Jose, CA 95112  
Phone: (408) 292-2214  
Fax: (408) 292-2733

### Mexico Service Center

Mountz Mexico SA de CV Chihuahua  
Av. Cristobal Colon #15343  
Col. Paseos de Chihuahua  
Chihuahua, Chih. Mexico CP 31125  
Phone: (614) 481-0023  
Fax: (614) 481-0053

[www.mountztorque.com](http://www.mountztorque.com)

[sales@mountztorque.com](mailto:sales@mountztorque.com)

Download a "Service Form" and include a copy when you send the tools in to be serviced.

Looking for fasteners?

[www.mrmetric.com](http://www.mrmetric.com)



### Service

Mountz Inc. features an experienced calibration and repair staff. Our trained technicians can calibrate and repair most any tool. Mountz provides rapid service with quality that you can trust as we offer three state-of-the-art calibration lab and repair facilities that can calibrate up to 20,000 lbf.ft.

With over 40 years of experience, Mountz's in-depth knowledge of torque is reflected in our tool's craftsmanship and our ability to provide solutions to both common and uncommon torque applications. Mountz is an ISO 9001 and ISO 17025 company.