

## STB (Cam-Over Wrench) Operating Instructions

Rev 2.0 (11/22/2011)

### Calibrating Torque Wrenches

To calibrate torque wrenches either use a torque tester or torque sensor within the range of the torque wrench. For cam-over torque wrenches calibrate torque in "Peak" mode with an torque tester or torque sensor. Make sure you apply the torque slowly and smoothly.

1. Select a torque tester or torque sensor that covers the torque range of the STB wrench. Connect wrench to the torque tester or torque sensor using the appropriate adapters as needed (not supplied).
2. Apply torque clockwise slowly until wrench 'breaks' and note reading.
3. Adjust wrench to required torque setting.
4. Test and repeat adjustment as necessary to obtain desired value.
5. Recalibrate torque wrench at prescribed intervals.

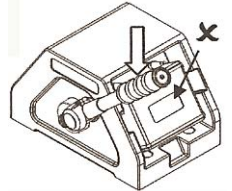

### Adjusting Torque Setting

1. Remove end cap from wrench and insert special adjusting key.
2. The special Adjusting Key is an articulated design. When in use the two halves are set at 90°, this allows downward force to be exerted on the Sliding Lock while rotating the Adjusting Screw.
3. Turn clockwise to increase torque and counter clockwise to decrease torque. Do not adjust torque above or below the recommended torque ranges. Tighten end cap back on.

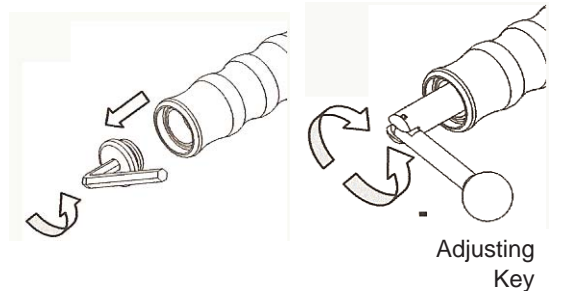

### Construction & Operation of M-TALD System

The STB wrenches features the M-TALD (Mechanical Torque Adjustment Locking Device) system. The M-TALD is an easy to use locking device for adjusting the torque of the STB. It's a positive, mechanical locking system that does not rely on friction for movement, and does not require a secondary locking device. It's operated using a single key.

1. M-TALD comprises of three main parts: The Adjusting screw, the spring-loaded Sliding Lock and the Castellated Lock Ring. These are assembled into a single, self-contained unit and held together by a retaining ring.
2. The assembly is screwed into the wrench handle tube, with the location lugs of the Lock Ring engaging with specially formed grooves.
3. An inward force has to be exerted onto the Sliding Lock, through the special adjusting key, while the Adjusting Screw is being rotated.
4. As soon as the inward force is released, the spring-loaded Sliding Lock engages with the teeth of the Lock Ring, further rotation of the Adjusting Screw is not possible.
5. The Castellated Lock Ring has ten teeth, allowing the Adjusting Screw to be set at increments of 36°. The resolution of each increment varies with each model of the tool and are, generally, as follows:  
STB 35                      0.15 Nm

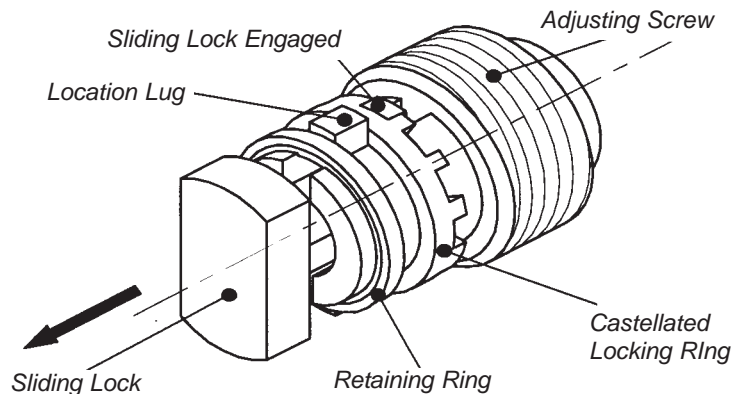

### Applying Torque

1. Slide "head" on to the end of wrench. Align the pin with the head's pin slot.
2. Tighten nut or bolt by applying a steady even pull using built in ratchet as necessary. When pre-set torque is reached, the wrench will 'break.'
2. The wrench will automatically reset itself for the next application.
3. With its unique design, it's impossible to over tighten beyond the preset load.

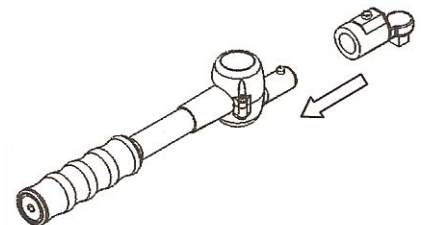

# STB (Cam-Over Wrench) Operating Instructions

Rev 2.0 (11/22/2011)

## Calibrating Torque Wrenches

To calibrate torque wrenches either use a torque analyzer or torque transducer within the range of the torque wrench. For cam-over torque wrenches calibrate torque in "Peak" mode with an analyzer or transducer. Make sure you apply the torque slowly and smoothly.

1. Slide "head" on to the end of wrench. Align the pin with the head's pin slot.
2. Select a torque analyzer or transducer that covers the torque range of the STB the torque analyzer or transducer using the appropriate adapters as needed (not supplied).
3. Apply torque clockwise slowly until wrench 'breaks' and note reading.
4. If the torque reading is incorrect, then remove torque wrench from torque analyzer or sensor.

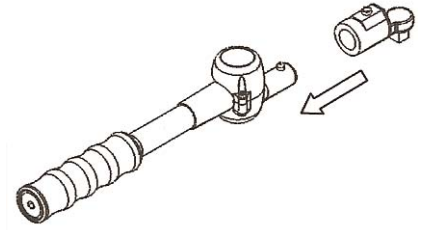

wrench. Connect wrench to

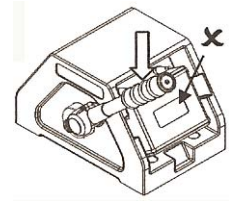

## Adjusting Torque Setting

1. Remove end cap from wrench and insert special adjusting key supplied with unit.
2. The special Adjusting Key is an articulated design. When in use the two halves are set at 90°, this allows downward force to be exerted on the Sliding Lock while rotating the Adjusting Screw.
3. Turn clockwise to increase torque and counter clockwise to decrease torque. Do not adjust torque above or below the recommended torque ranges. Tighten end cap back on.
4. Test and repeat adjustment as necessary to obtain desired value.
5. Tighten end cap back on once the correct torque setting is achieved.

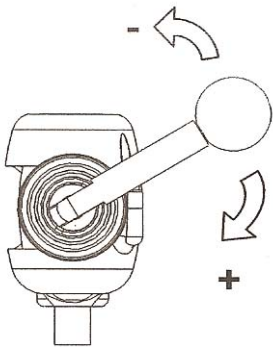

## Testing & Servicing

In order to maintain accuracy, it is crucial that torque control measuring equipment be calibrated regularly.

We recommend a general once a year calibration interval. However, it is the user's organization that must determine suitable intervals based upon equipment performance, application, degree of usage and management objectives.

For calibration, re-adjustment or repairs, please send the tool to one of our 3 service locations.

## Mountz Service Locations

### Eastern Service Center

19051 Underwood Rd.  
Foley, AL 36535  
Phone: (251) 943-4125  
Fax: (251) 943-4979

### Western Service Center

1080 N.11th Street  
San Jose, CA 95112  
Phone: (408) 292-2214  
Fax: (408) 292-2733

### Mexico Service Center

Mountz Mexico SA de CV Chihuahua  
Av. Cristobal Colon #15343  
Col. Paseos de Chihuahua  
Chihuahua, Chih. Mexico CP 31125  
Phone: (614) 481-0023  
Fax: (614) 481-0053

[www.mountztorque.com](http://www.mountztorque.com)  
[sales@mountztorque.com](mailto:sales@mountztorque.com)

Download a "Service Form" and include a copy when you send the tools in to be serviced.

Looking for fasteners?  
[www.mrmetric.com](http://www.mrmetric.com)

