

STC 30 Plus v4.3 Operation Instructions

(Rev 3.0 9/9/11)



RoHS



Power Supply for Electric Screwdrivers



STC30 Plus (v4.3) Transformer

(Rev 3.0 9/9/11)

Power
Securely place the power cord into the back of the STC30 Plus. Flip the switch on the back to turn on the unit: Light turns Green.

Connecting Electric Screwdriver
Before connecting the electric screwdriver, make sure the little switch in the lower bottom right of the STC 30 Plus (v4.3) is positioned in the proper setting (EF or K). See diagram. Only operate tool in proper "Mode" setting.

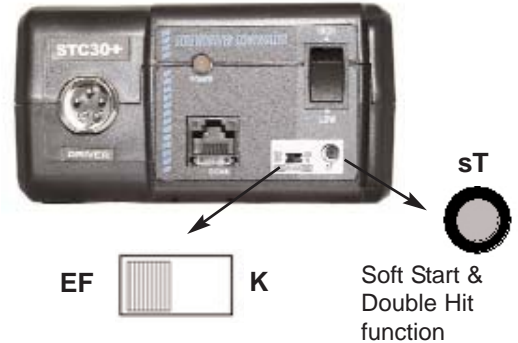

EF Mode
Low = Output is 20VDC
High = Output is 30VDC
Electric Drivers to use in EF Mode:
A4500- 5000
SS300-7000
CL2000-7000
EF080-120

K Mode
Low = Output is 30VDC
High = Output is 38VDC
Electric Drivers to use in K Mode:
K150-450

Make sure the switch is correct position before operating. Either EF or K mode.

Note: There are two models of the STC30 Plus v4.3
Item #145683 Operates: A-Series, CL-Series, EF-Series, K-Series
Item #145684 Operates: SS-Series

1. Attach cord of the electric screwdriver to the transformer. Make sure notch in plug lines up with the notch in the socket. Tighten knurled ground ring.
2. Select HIGH & LOW speed button. Select the appropriate speed for your application.
3. Turn driver on and check for proper rotation. FOR-clockwise, REV-counterclockwise.
4. To apply torque, squeeze the lever (For Push-to-Start models place light downward pressure on the nose of the driver). The driver will automatically stop when the preset torque has been reached.

Soft Start Mode
Press the "sT" button in the lower bottom right. The power light will blink once and turn **Yellow**, which indicates that you are in Soft Start mode. There are 4 different time settings for the Soft Start mode which are (0.2, 0.3, 0.5, & 0.6 seconds). When you select this mode it starts at 0.2 seconds.

The unit has EEP ROM, which allows the settings for the soft start and double hit to be kept once an operator turns off unit and then back on. Example: If the transformer is set at the 0.6 seconds setting for the soft start mode and the unit is turned off, it will keep that setting when unit is turned on.

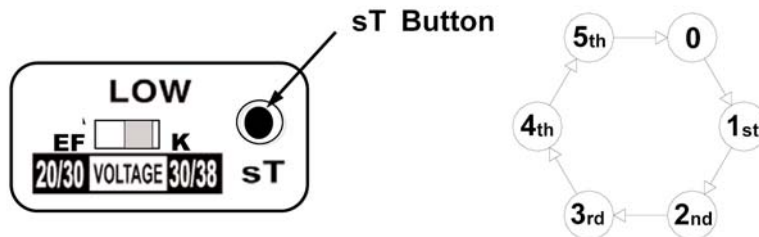

Push "sT" Button	Function	LED Light
0	Standard	Green
1st	Soft Start 0.2 Seconds	Yellow Light Blinks Once
2nd	Soft Start 0.3 Seconds	Yellow Light Blinks Twice
3rd	Soft Start 0.5 Seconds	Yellow Light Blinks Three times
4th	Soft Start 0.6 Seconds	Yellow Light Blinks Four times
5th	Double Hit Mode	Red

Quick Reminder
Green Light = Operating in Standard mode
Yellow Light = Operating in Soft Start mode
Red Light = Double Hit mode

Note: The settings should be such that the soft start cycle is completed during the free run portion of the cycle before the fastener begins to torque up.

STC30 Plus (v4.3) Transformer

(Rev 3.0 9/9/11)

Double Hit Mode

The Double Hit mode is for very soft joint applications. When an electric screwdriver runs down a fastener and the tool clutches off once the preset torque is achieved there can be some joint relaxation that can occur. The Double Hit mode has the electric screwdriver perform a second hit to stabilize the torque for joint relaxation.

Joint relaxation is caused by the surface of part(s) embedding or by "soft parts" such as gaskets, plastics or spongy material, which collapses under the clamping force created in a torque condition. For Hard Joint applications there is no need to use the Double Hit mode.

Press the "sT" button continuously until the power light turns **Red**.

The clutch of the electric driver works twice at the set torque under the "Double Hit" mode. The Double Hit will increase the repeatability accuracy at the target torque by double checking.

Note!



The STC 30 Plus models that are designed with Double Hit Mode and Soft Start mode features are not functional with any BF-Series electric screwdrivers. The Double Hit Mode and Soft Start mode features are built-in to the "Plus" models of the BF-Series electric screwdrivers.

OCP (Over Current Protection)

The power will shut down automatically when the current exceeds 12 - 13A. The controller should be reset by turning off the power switch for one minute and turned back on. If the current is not over the limit, power will turn on.

There is another OCP in a secondary circuit. The power will be disappear for 5 seconds when the current is over 4A over 3 seconds or when current is over 6A over 0.5 seconds. The transformer recovers automatically. The transformer gives an alarm signal by blinking Green and Orange color on the LED lights along with beep buzzer sound.

Description		Primary OCP	Secondary OCP	
Detection	Limit current	12 ~ 13A	Condition A 4A	Condition B 6A
	Time duration	immediately	3 sec.	0.5 sec.
Protection		Whole power shuts down permanently	Output power disappears for 5 sec.	
Protection Signal	LED	no	blinking Green — Orange — Off	blinking Orange — Off
	Buzzer	no	Normal frequent beep On/Off	Higher Frequent beep On/Off
Recovery		Turn off the power switch and on after 1 minute	Auto recovery after 5 sec.	

Over Heat Protection

The thermistor will shut down whole power supply if the unit over heats. The controller should be reset by turning off the power switch for one minute and turned back on. If the current is not over the limit, power will turn on.

Ratcheting Clutch Alarm

An alarm and break system notifies you when the ratcheting clutch occurs with an electric screwdriver. If the tool ratchets continuously 5 or 6 times, the STC-30 Plus will provide a buzzer alarm along with the red LED light Also it will stop the output power for 5 seconds as a secondary protection.

STC30 Plus (v4.3) Transformer

(Rev 3.0 9/9/11)

Connector and Cables (These cables are included with Scout Screw Counter)

Cable for connecting Scout to the STC30 Plus (Item #14-801120)

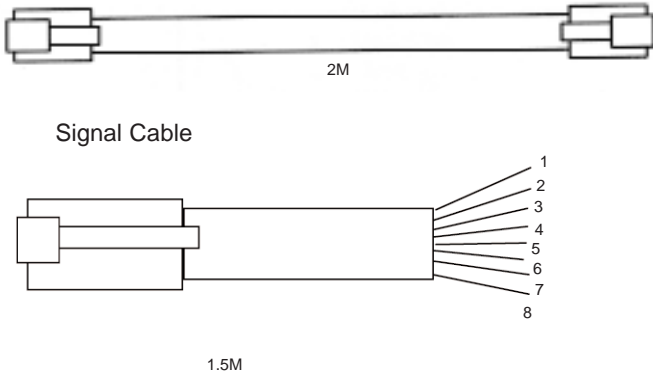

RJ-11
Modular Jack



Pin No.	Color	Function
1	Solid Orange	Not Used
2	White/Orange	Stop
3	Blue	Start
4	White/Blue	DC(-)
5	Green	Driver Lock
6	White/Green	Driver Lock
7	Brown	N/A
8	White/Brown	Not Used

Output Pin Connection

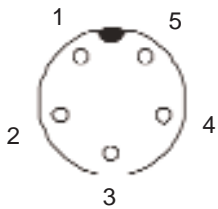

- 1: Motor (+)
- 2: Limit
- 3: Motor (-)
- 4: Drive
- 5: Ground



Note!

Do not connect any other electric screwdriver that's not listed to be used with the transformer. It may cause electric shock, fire, damage to the tools or operator injury.

Input voltage selection

230VAC Selected

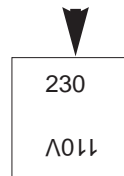

110VAC Selected

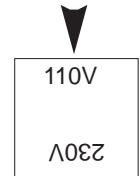

Timing chart for Start / Stop Signal



STC30 Plus (v4.3) Transformer

(Rev 3.0 9/9/11)

PLC connections

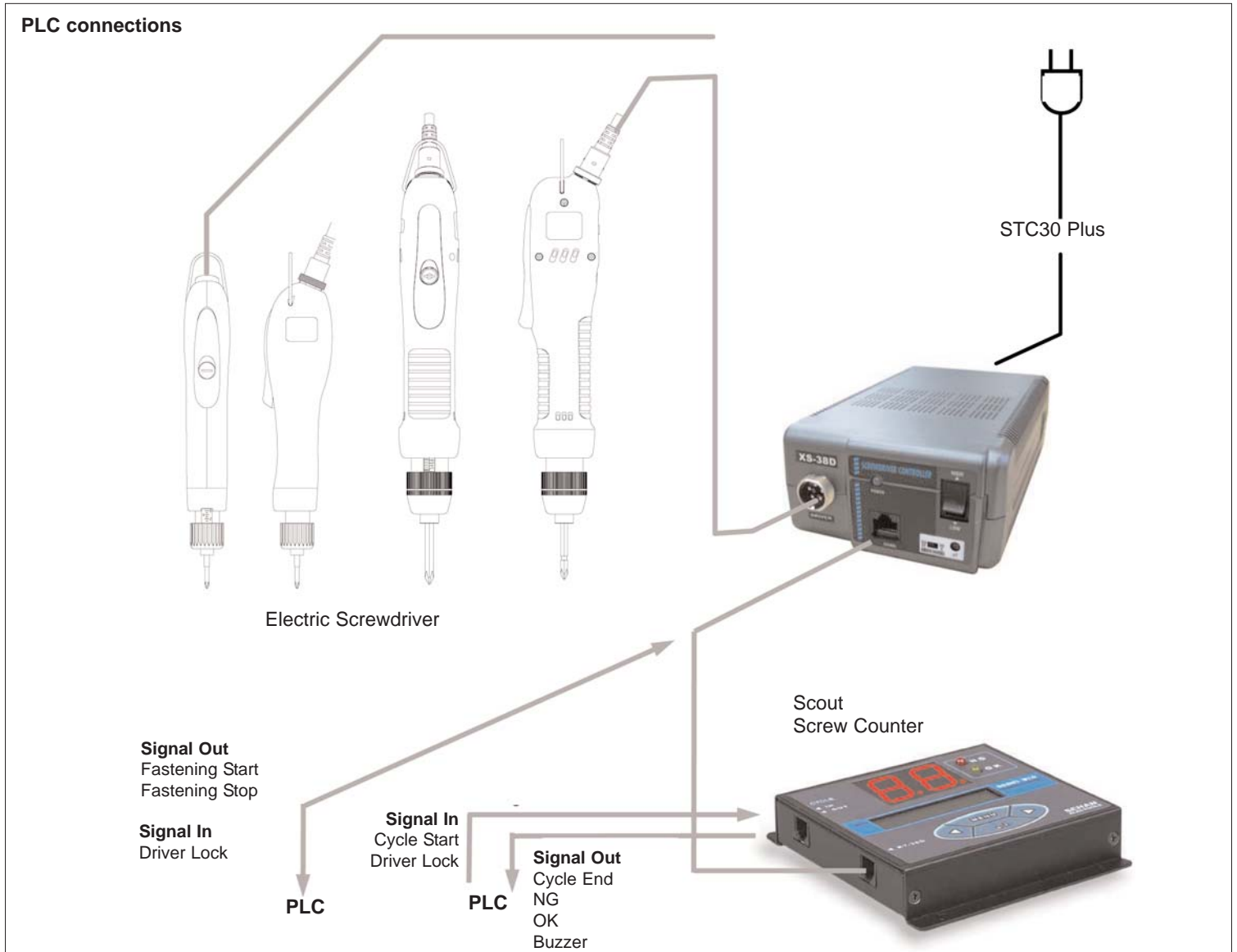

Interface for Start / Stop Signal & Driver Lock

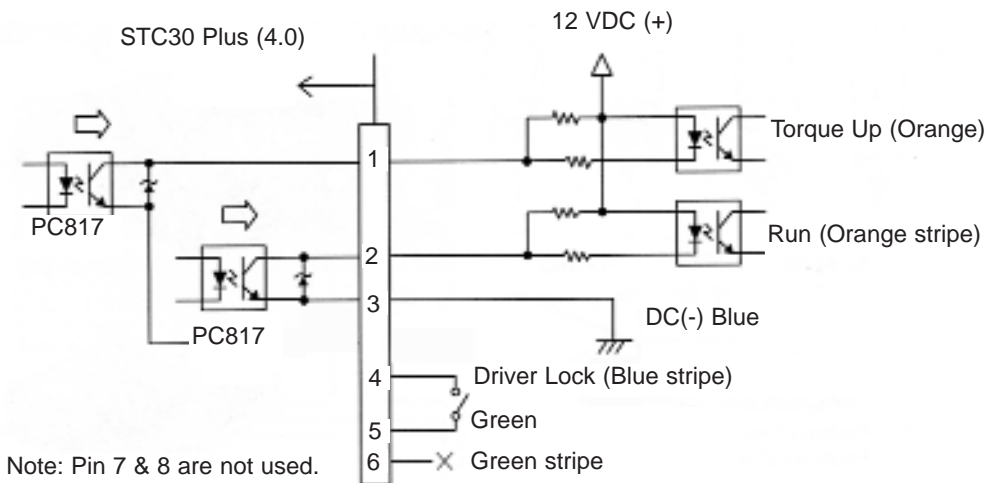

STC30 Plus (v4.3) Transformer

(Rev 3.0 9/9/11)

U-3B Interface Converter (Accessory)

The PLC interface converter provides three types of signals by converting the open collector signal from STC 30 Plus v4.3 & STC 40.

Model: U-3B
 Item #145753
 Size (WxDxH): 3" x 2 3/8" x 1"
 Weight 3.6 oz



Types of Signals:

- Open Collector by Opto-Coupler (Reversed)
- Relay Contact (Normal Close)
- Relay Contact (Normal Open)

Opto Coupler: 12-24V (10mA max)
 Relay Contact: 30VDC 1a Max

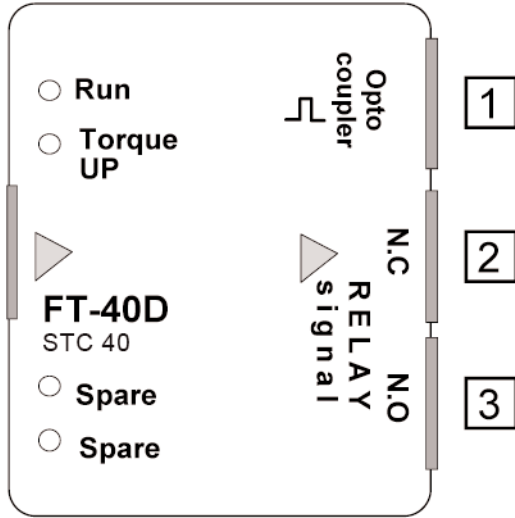

Relay power off when not use



8PIN Configuration and Output

No	Color	Interface Signal	FT-40D STC30 Plus v4.3	U-3B Interface converter I/O port		
				1	2	3
1	ORANGE	Spare				
2	ORANGE STRIPE	Torque Up				
3	BLUE	Motor Run				
4	BLUE STRIPE	Common for 2&3 wire				
5	GREEN	Motor Lock or Remote Start				
6	GREEN STRIPE					
7	BROWN	No use				
8	BROWN STRIPE	Spare				

STC30 Plus (v4.3) Transformer

(Rev 3.0 9/9/11)

U-3B interface converter I/O details

1 Opto-coupler port

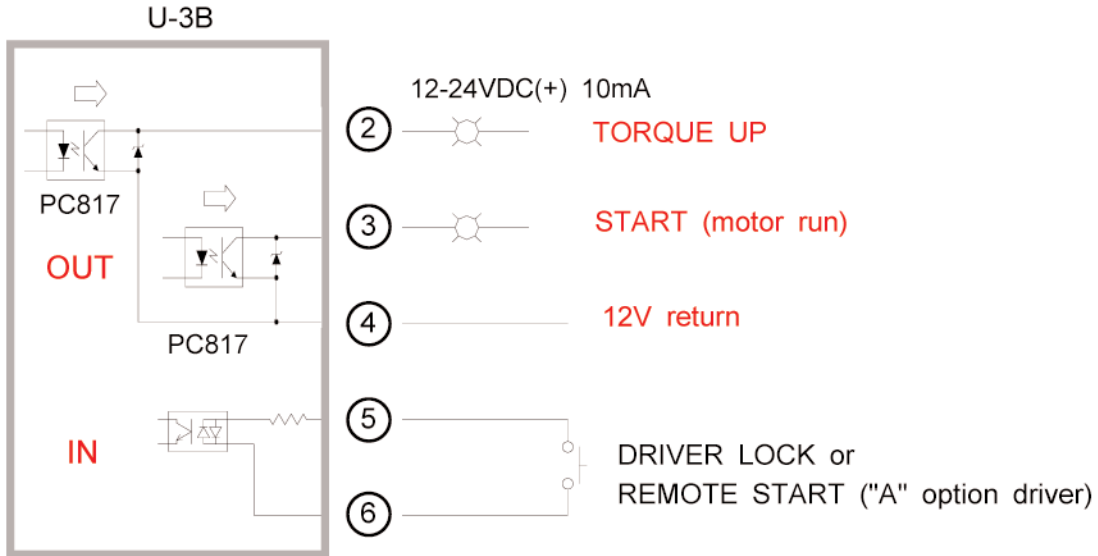

2 & 3 Relay N.C & N.O port

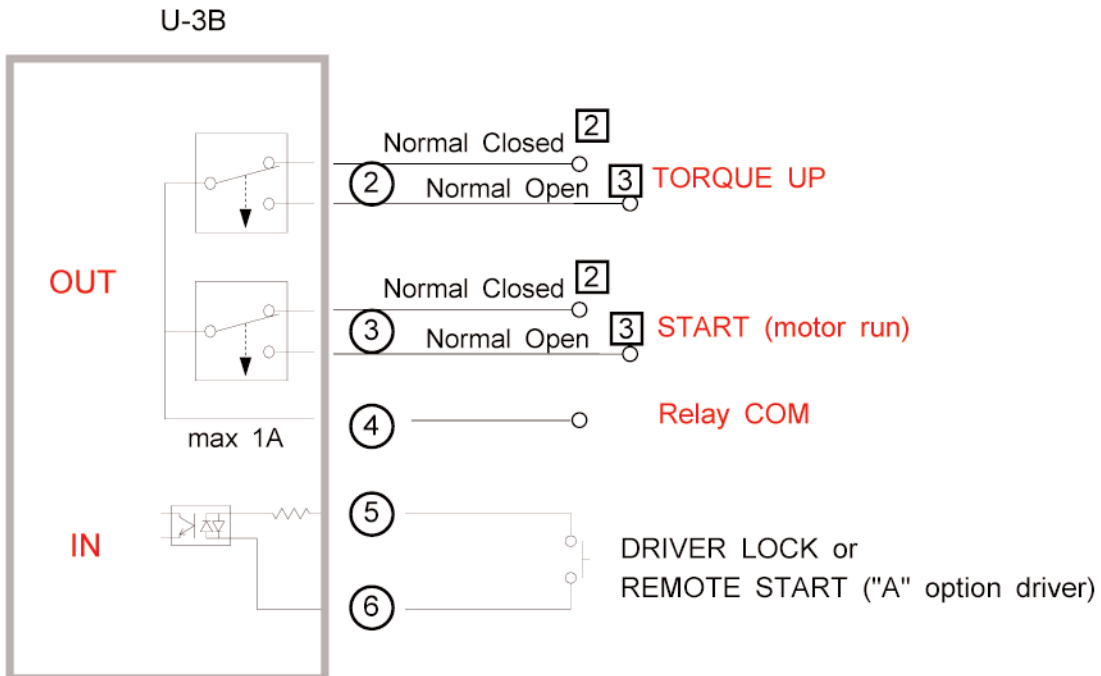

STC30 Plus (v4.3) Transformer

(Rev 3.0 9/9/11)

Mountz Calibration & Repair Services

Mountz Inc. features an experienced calibration and repair staff. Our trained technicians can calibrate and repair most any tool. Mountz provides rapid service with quality that you can trust as we offer three state-of-the-art calibration lab and repair facilities that can calibrate up to 20,000 lbf.ft.

With over 45 years of experience, Mountz's in-depth knowledge of torque is reflected in our tool's craftsmanship and our ability to provide solutions to both common and uncommon torque applications. We perform calibrations in accordance with ANSI/NCSL-Z540. Mountz is dedicated solely to the manufacturing, marketing and servicing of high quality torque tools.

Mountz is an ISO 9001 certified and ISO 17025 accredited company.

Tool Service & Repair Capability

- Torque Wrench Calibration: Click Wrench, Dial Torque Wrench, Beam Wrench, Cam-Over & Break-Over Wrench
- Torque Screwdrivers: Dial, Micrometer, Preset & Adjustable
- Torque Analyzers/Sensors: All brands
- Electric Screwdrivers: All brands
- Air Tools: All brands
Impact Wrenches, Drills, Pulse Tools, Grinders, Percussive Tools, Air Screwdrivers, Nutrunners, DC Controlled Nutrunners
- Torque Multipliers: All brands

Mountz Torque Testers and Calibration Equipment

Torque tools go out of calibration with use. Calibrating a torque tool is a fine-tuning process of bringing the tool back within its tolerance. Torque testers can also be used for quick tools tests on the line or in the lab to determine whether torque tools are holding a given setting.

A regular torque tool calibration and re-calibration guarantees the operator repeatable accuracy and adherence to international standards. Torque testing also ensures torque equipment is operating to peak performance and can highlight potential tooling problems before they arise perhaps due to tool wear or broken components.

Controlling torque is essential for companies to ensure their product's quality, safety and reliability isn't compromised. The failure of a three-cent fastener that isn't properly tightened can lead to catastrophic or latent failures. Fasteners that are insufficiently torqued can vibrate loose and excessive torque can strip threaded fasteners. Using a quality torque tool has become increasingly important for many companies to ensure that proper torque is being applied and maintains gauge requirements associated with the ISO 9001 Quality Standard. Look for the Mountz hexagon logo - it's a stamp for quality tools, service and knowledge in the field of torque control.

Mountz Service Locations

Eastern Service Center

19051 Underwood Rd.
Foley, AL 36535
Phone: (251) 943-4125
Fax: (251) 943-4979

Western Service Center

1080 N.11th Street
San Jose, CA 95112
Phone: (408) 292-2214
Fax: (408) 292-2733

Mexico Service Center

Mountz Mexico SA de CV Chihuahua
Av. Cristobal Colon #15343
Col. Paseos de Chihuahua
Chihuahua, Chih. Mexico CP 31125
Phone: (614) 481-0023
Fax: (614) 481-0053

www.mountztorque.com
sales@mountztorque.com

Download a "Service Form" and include a copy when you send the tools in to be serviced.

Looking for fasteners?
www.mrmetric.com

