

TSN55 (w/Adjusting Key Tool Kit)

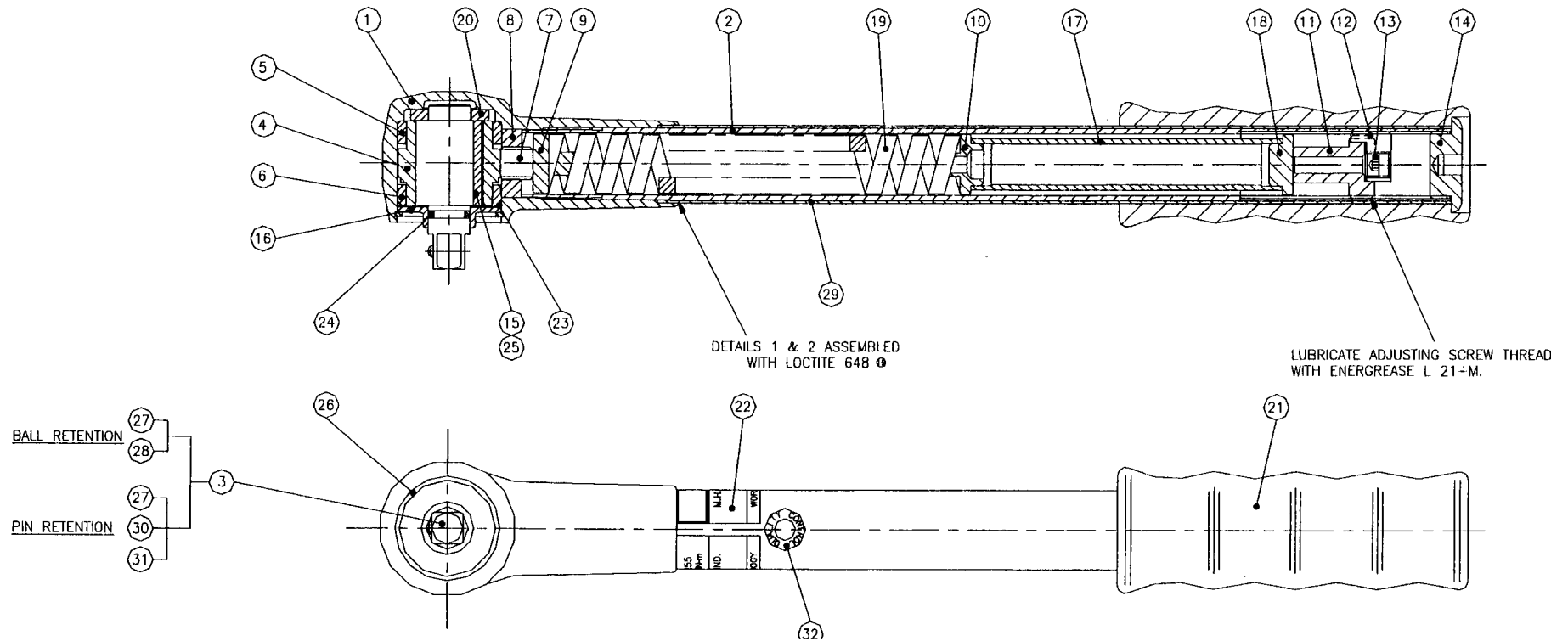

1. Assembly procedure detail 1 & 2. Assemble Bush (Rear) into head. Insert roller guide into head and loctite handle in place. Clean off excess loctite.
2. Residual Torque from top CAM form to rest position shall not exceed 7.5 N.m. Torque required to turn spindle ratchet mechanism within CAM I/D shall not exceed 1.0 N.m.

Adjusting Tool Kit for TSN 125

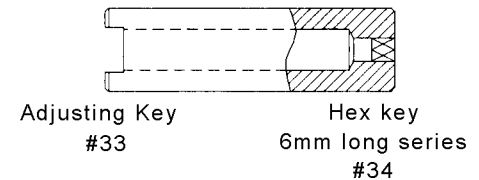

TSN55 (w/Adjusting Key Tool Kit)

Ref#	Part#	Qty	Description	Ref#	Part#	Qty	Description
1	20-C59650	1	Head TSN55	19	20-A60310	1	Main Spring
2	20-B59660	1	Handle	20	20-A73202	1	Thrust Bearing
3	20-C59671	1	Spindle - R.H. (Ball Retention)	21	20-A74741	1	Hand Grip
	20-C59672	1	Spindle - R.H. (Pin Retention)	22	-	1	Label
	20-C68001	1	Spindle - L.H. (Ball Retention)	23	20-P10120	1	O-Ring
	20-C68002	1	Spindle - L.H. (Pin Retention)	24	20-P10130	1	O-Ring
4	20-C86070	1	CAM - 5 Lobe (R.H.)	25	20-P59850	4	Spring
	20-C87040	1	CAM - 5 Lobe (L.H.)	26	20-P10140	1	Retaining Ring
5	20-A59690	1	Bush - Rear	27	20-A10032	1	Spring (Ball Retention model)
6	20-A59700	1	Bush - Front	28	20-P10610	1	Steel Ball 5/32 Dia (Ball Retention model)
7	20-A32790	1	Roller	29	20-P10220	1	Polyshrink Sleeving - Red
8	20-A59710	1	Roller Guide		20-P18050	1	Polyshrink Sleeving - Yellow (LH model)
9	20-A59720	1	Pressure Pad	30	20-A79861	1	Retention Pin (Pin Retention model)
10	20-A59730	1	Spacer End Spigot	31	20-A79871	1	Ring (Pin Retention model)
11	20-A98060	1	Adjusting Screw	32	20-A67691	1	Quality Control Label
12	20-A98090	1	Lock	33	20-A98110	1	Adjusting Key
13	20-P22280	1	SKT S/Screw M8x8	34	20-P22250	1	HEX Key Long Series 6mm
14	20-A50391	1	End Plug				
15	20-A59770	2	Pawl				
16	20-A59780	1	Seal Cover				
17	20-B59790	1	Spacer Tube				
18	20-A59800	1	Spring End Pad				