

Balancer Operation Instructions (MZ-198, MZ-231 & MZ-264 models)

Rev 1.7 (4/13/17)

Selecting the Correct Tool Balancer Model

1. Select the proper tool balancer for loading the weight of a tool/object that's going to be suspended.
2. When selecting the tool balancer, you need to consider total load of a tool object (including tool, power cord/cable, air hose or other attachments).

Example

Weight of Power Tool + Weight of Attachment = Weight of Total Load
 155 lbs + 10 lbs = 165 lbs

Select Tool Balancer model MZ-198

3. In an another scenario if the total weight load is 198 lbs, which is the maximum capacity of the MZ-198, then it's recommended to select the next size tool balancer as it could shorten the life of the smaller model.

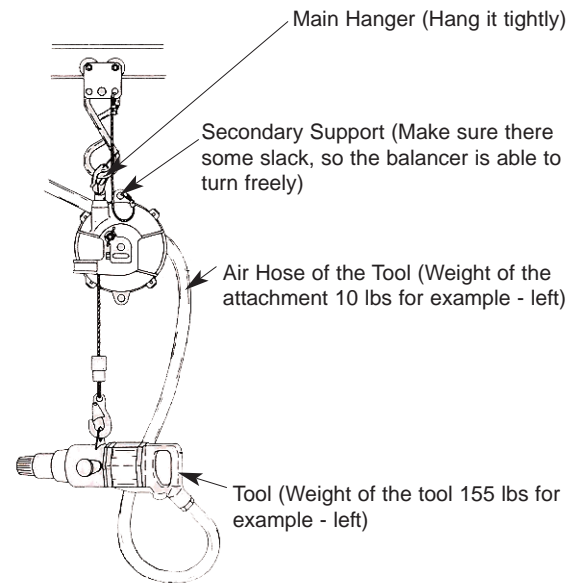

Mounting

1. Both the Main Hanger and the Secondary Hanger should be used together to hold the balancer securely. The Main Hanger should be attached to a hanging device. Then a security chain, wire, etc. should be connected to the Secondary Hanger (Should not be longer than 100mm in case the main hanger is damaged).
2. Check if the weight of the tool being loaded is appropriate before connecting it to the Load Hook.
3. The tool balancer should be in a position to operate smoothly.
4. When installing two or more tool balancers on a trolley system, avoid the possibility of the balancers colliding.
5. Always ensure the top hook (Main Manger) is free to rotate.

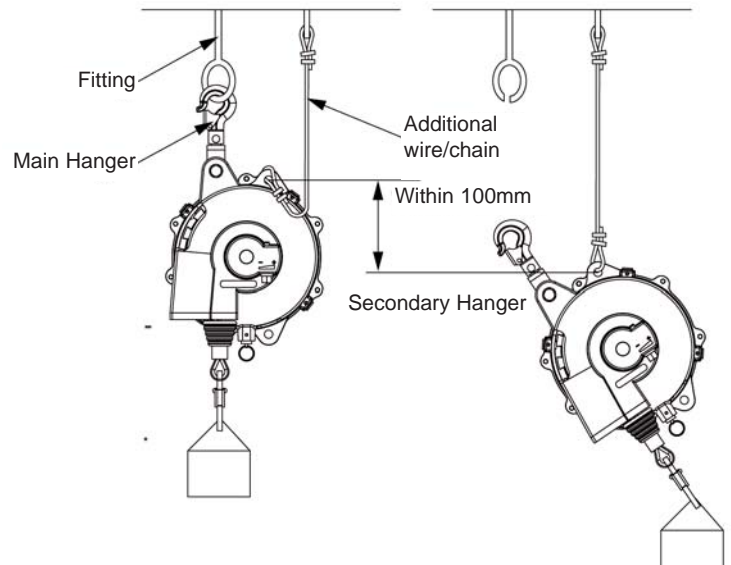

Spring Tension Adjustment

1. When adjusting the spring tension, remove the tool from the bottom load hook before operating the adjustment.
2. Check the total weight of tool (including accessory attached) is within range of the tool balancer.
3. To increase the tension, using a wrench turn the "worm" clockwise. To decrease the tension, using a wrench turn the "worm" counterclockwise. You can judge approximate weight through the gauge.
4. Avoid adjusting the tension above or below the rated capacity of the tool balancer. If the spring is set above maximum capacity, it will shorten the stroke of the cable and decrease the life of the spring. And, if the spring is set lower than the minimum capacity, the safety device will act and stop operation on the tool attached to the tool balancer. The Tool should be removed from the Tool Balancer.

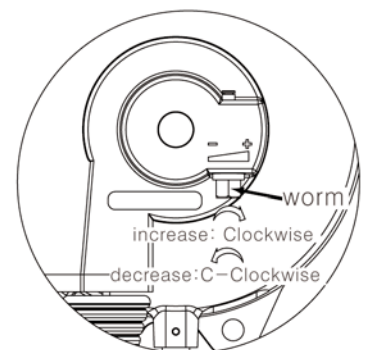

Balancer Operation Instructions (MZ-20 through MZ-154 models)

Rev 1.7 (4/13/17)

Checking Working-Range (Stroke)

1. Check that the cable length is suitable for the working condition.
2. Adjust the height of the tool balancer if needed.

Note: Pulling and operating the cable to its maximum stroke could cause damage to the balancer and shorten the spring durability.

Operating the Tool Balancer

Drum rotation lock set/release

1. Drum rotation lock set: Pull the manual stopper ring to arrow direction until it's clicking.

Drum rotation lock release

2. Pull again the manual stopper ring to arrow direction until the drum rotation is unlocked.

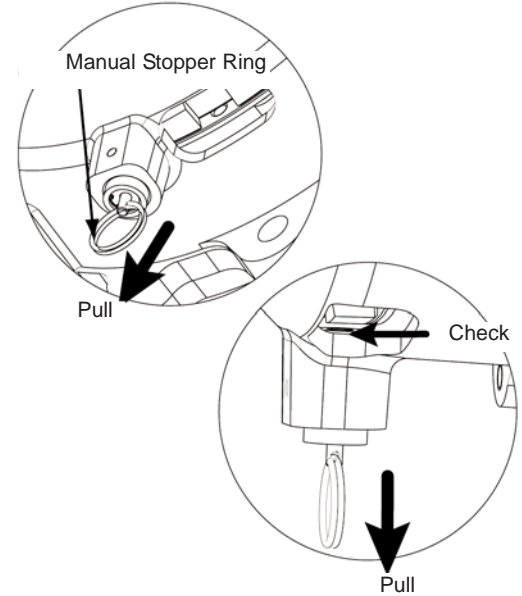

Spring Tension (Weight Setting) Adjustment

1. When adjusting the spring tension, remove the tool from the bottom load hook before switching the tool (device). Adjust the cable and place current tool at a convenient height for making the exchange.
2. Pull the manual stopper ring and set the drum rotation to the lock setting. For checking the drum rotation is locked move the cable upward and downward. If the drum rotation is locked, the cable will not move. Also check the stopper pin has popped up through the hole (refer to the picture).
3. Detach the tool (device) from the cable hook.
4. Adjust the weight setting of the tool balancer to be suitable with the new tool (device) that will be attached. To increase the tension, turn the "worm" clockwise. To decrease the tension, turn the "worm" counterclockwise. You can judge approximate weight through the gauge.
5. After adding the new tool (device), release the drum rotation lock.



- Check THE DRUM ROTATION IS LOCKED before detaching the tool (device). It can cause personal injury or damage to the balancer if the tool (device) is detached from the cable hook when the drum rotation is not locked safely.

- NEVER release the drum rotation lock when no tool (device) is attached. It can cause personal injury or damage of the balancer.

- Adjust the weight setting before releasing drum rotation lock if the weight of the new tool is different from the current tool. It can personal injury or loss of property because of rapid retracting of the cable or tool (device) falling.

Balancer Operation Instructions (MZ-20 through MZ-154 models)

Rev 1.7 (4/13/17)

Replacement of the Cable (Image A)

1. Pull the entire length of the cable out of the drum.
2. Pull the manual stopper ring and set the drum rotation to the lock setting.
3. Take attached equipment off load hook.
4. Push the cable upward (see drawing for arrow direction). The cable and cable bushing should be pop up from the drum.
5. Remove the cable bushing and pull the cable downward. The cable will be detached from the drum.
6. Remove the shock-absorber and collar from the old cable and attach to the new cable.
7. Insert the end of cable into the hole of drum. Assemble the cable bushing and pull the cable downward.
8. Attach the tool (device) to cable hook and release the drum rotation lock.

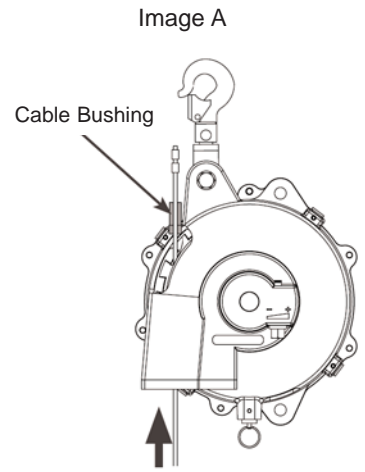

Replacement of the Insert-Guide (Image B)

1. Detach the cable from the drum. (Refer to “Replacement of the Cable” step 1 ~ step 5)
2. Unscrew the insert-guide and replace it.
3. Reassemble the cable to the drum. (Refer to “Replacement of the Cable” of step 6~ step 8)

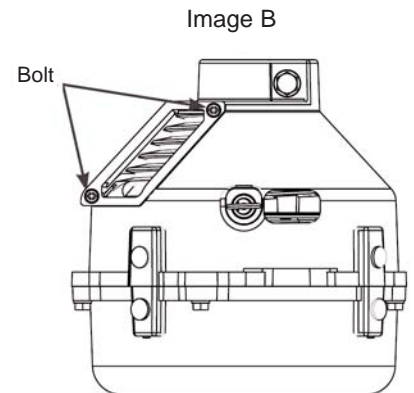

Assembly & Disassembly of the Cover (Image C)

1. Remove the E-ring from the end of the worm.
2. Loosen the worm (counter clockwise) until it is off.
3. Remove the 4-safety arms (Refer to parts list drawing).
4. Unscrew the cover and detach the case.
5. Assembly is reverse order of disassembly.

Cable is Jammed Between Case and Drum

1. Pull the cable strongly with the tool (device) that is installed.
2. If the cable can not be pulled, open the cover (Refer to “Assembly & Disassembly of the Cover” listed above).
3. Check the status of the cable. Replace cable if it’s twisted, kinked or damaged.
4. Rewind the cable and assemble cover.

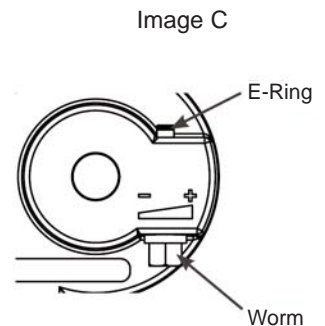

Balancer Operation Instructions (MZ-20 through MZ-154 models)

Rev 1.7 (4/13/17)

Troubleshooting		
Issue	Cause	Solution
<p>The cable is almost locked up</p>	<p>Manual stopper is activated</p> <p>Cable is jammed between the case and drum</p>	<p>Release the manual stopper (Refer to “Drum rotation lock set/release” page 2)</p> <p>See page 3 for fixing it</p>
<p>The cable moves a little bit.(80~160mm)</p>	<p>Fall prevention device is activated because weight setting is under the minimum weight capacity.</p> <p>Fall prevention device is activated because the spring is broken</p>	<p>- Increase weight setting of the tool balancer - Incorrect Tool Balancer is being used. Use correct size Tool Balancer for the application.</p> <p>Replace the spring case assembly.</p>

Replacement of Spring Case

Disassemble the tool balancer in this order (reference the exploded view drawing in the parts list document).

1. Pull the manual stopper ring and set the drum rotation to the lock setting. Detach the tool (device) from cable hook.
2. Detach the tool balancer from the attached fitting and put it down on a worktable.
3. Remove the E-ring (8) from the end of worm.
4. Decrease the weight setting by turning the worm counter clockwise. The worm will be separated from the case soon after the tension fades away.
5. Unscrew the set-screw (4,34) and detach the safety-arm (5,33).
6. Detach the cable from drum. (Reference page 3 “Replacement of the Cable”)
7. Open the cover by unscrewing the bolt (38) 6 each. Together, separate the spring-case (24), drum (22), spindle (21) from the case. Note: Replace the safety-device pin (26) when replacing the spring case. It may not work properly due to the damage when it’s activated.
8. Detach the spindle (21).
9. Unscrew hex head socket bolt (30) and separate the drum from the spring case assembly (24).
10. Replace the part - spring case assembly (24). Replace the safety-device pin (26)
11. Assemble in reverse order of disassembly.
12. Wind the spring by turning the worm clockwise. The cable will be wound on the drum by turning the worm. Pull the cable lightly and hold it tightly in order to prevent the cable from being jammed between the case and drum until the cable is fully retracted into the case.
12. Continue to turning the worm until the weight setting is suitable.
13. Attach a weight (within the middle capacity of the balancer) on cable hook and adjust the spring tension again. Then set the gauge by set load. Unscrew the screw (37), which is at center of gauge. Adjust setting and tighten screw
14. Assemble the safety-arm. (referring right picture) The fall-prevention safety device may not work properly.

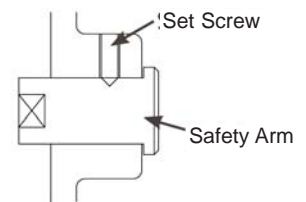

- NEVER separate the spring from the spring case. It could cause injury.
- Do not open the cover of the spring case.
- Replace the whole spring case assembly.

Balancer Operation Instructions (MZ-20 through MZ-154 models)

Rev 1.7 (4/13/17)

Maintenance and Inspection

For the purpose of preventing of accidental falling, inspection should be carried out at least once a month. If there are any wear or damaged parts to be found, stop using the tool balancer and replace it.



DANGER

- Always use genuine parts for replacement.

Periodic inspection check point

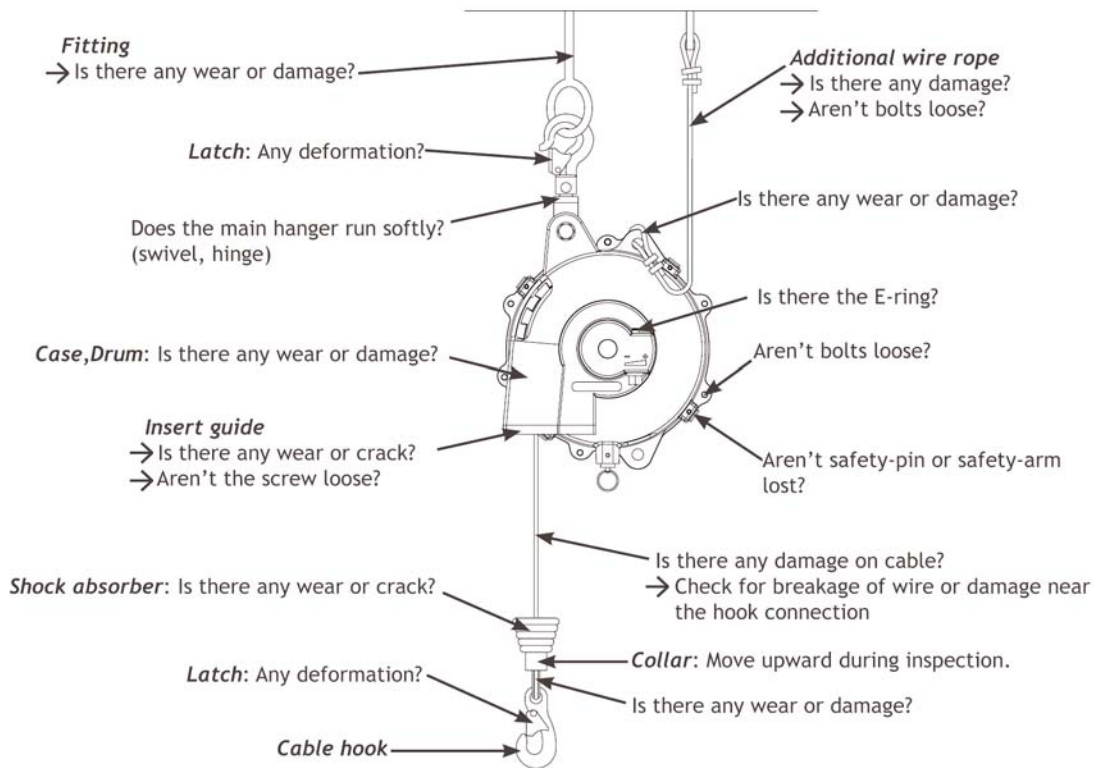

Balancer Operation Instructions (MZ-20 through MZ-154 models)

Rev 1.7 (4/13/17)

Tips on use of Tool Balancers and Secondly Support Chains

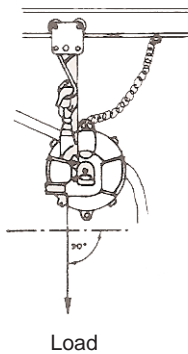

Keep load hanging perpendicular.

WRONG

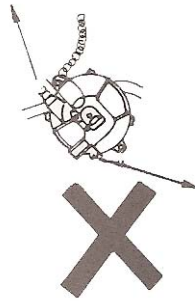

Working with load not perpendicular causes operator fatigue and excessive cable wear and drum wear.

Correct

Tool Balancer loaded on trolley

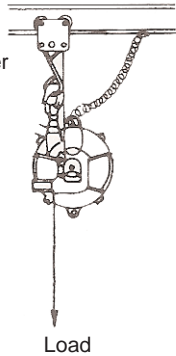

Trolley mount allows balancer to function properly and provides variable work area.

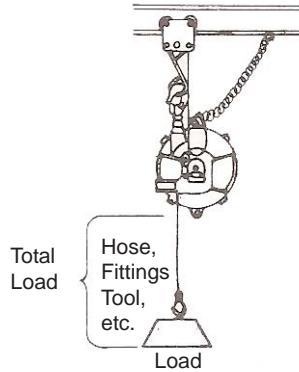

When planning tool balancer installation, consider total balancer load.

Mountz Service Locations

Eastern Service Center

19051 Underwood Rd.
Foley, AL 36535
Phone: (251) 943-4125
Fax: (251) 943-4979

Western Service Center

1080 N.11th Street
San Jose, CA 95112
Phone: (408) 292-2214
Fax: (408) 292-2733

www.mountztorque.com
sales@mountztorque.com



Twitter: @mountztorque

Download a "Service Form" and include a copy when you send the tools in to be serviced.

Looking for fasteners?
www.mrmetric.com

**mr.
metric**

Service

Mountz Inc. features an experienced calibration and repair staff. Our trained technicians can calibrate and repair most any tool. Mountz provides rapid service with quality that you can trust as we offer three state-of-the-art calibration lab and repair facilities that can calibrate up to 20,000 lbf.ft.

Since 1965, Mountz's in-depth knowledge of torque is reflected in our tool's craftsmanship and our ability to provide solutions to both common and uncommon torque applications. We perform calibrations in accordance with ANSI/NCSL-Z540. Mountz is dedicated solely to the manufacturing, marketing and servicing of high quality torque tools.