

Balancer Operation Instructions (MZ-20 through MZ-154 models)

Rev 2.2 (4/13/17)

Selecting the Correct Tool Balancer Model

1. Select the proper tool balancer for loading the weight of a tool/object that's going to be suspended.
2. When selecting the tool balancer, you need to consider total load of a tool object (including tool, power cord/cable, air hose or other attachments).

Example

$$\begin{array}{rccccccc} \text{Weight of Power Tool} & + & \text{Weight of Attachment} & = & \text{Weight of Total Load} & & \\ 14 \text{ lbs} & & 3 \text{ lbs} & & 17 \text{ lbs} & & \end{array}$$

Select Tool Balancer model MZ-20

3. In an another scenario if the total weight load is 20 lbs, which is the maximum capacity of the MZ-20, then it's recommended to select the next size tool balancer as it could shorten the life of the smaller model.

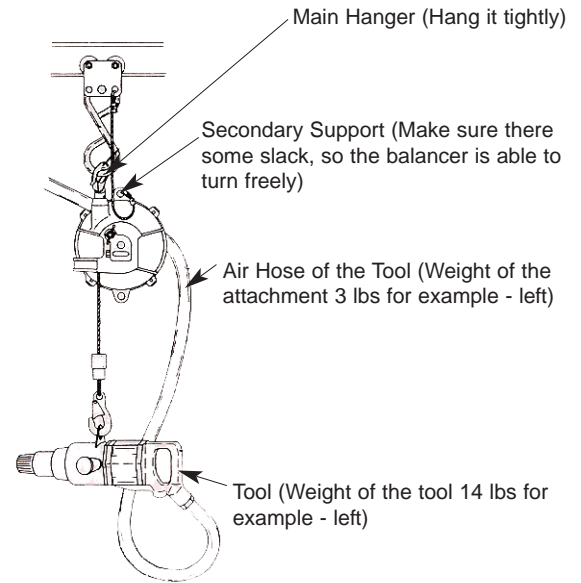

Mounting

1. Both the Main Hanger and the Secondary Hanger should be used together to hold the balancer securely. The Main Hanger should be attached to a hanging device. Then a security chain, wire, etc. should be connected to the Secondary Hanger.
2. Check if the weight of the tool being loaded is appropriate before connecting it to the Load Hook.
3. The tool balancer should be in a position to operate smoothly.
4. When installing two or more tool balancers on a trolley system, avoid the possibility of the balancers colliding.
5. Always ensure the top hook (Main Manger) is free to rotate.

Spring Tension Adjustment

1. When adjusting the spring tension, remove the tool from the bottom load hook before operating the adjustment.
2. To increase the tension, turn the "worm" clockwise. To decrease the tension, turn the "worm" counterclockwise. You can judge approximate weight through the gauge.
3. Avoid adjusting the tension above or below the rated capacity of the tool balancer. If the spring is set above maximum capacity, it will shorten the stroke of the cable and decrease the life of the spring. And, if the spring is set lower than the minimum capacity, the safety device will act and stop operation prematurely.

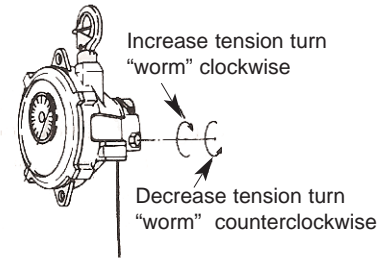

Replacing Parts of a Tool Attached to Tool Balancer

1. The following procedure should be followed if it's necessary to replace any parts on the tool attached to the tool balancer. The Tool should be removed from the Tool Balancer.

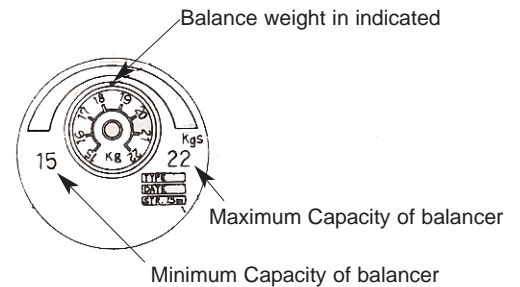

Balancer Operation Instructions (MZ-20 through MZ-154 models)

Rev 2.2 (4/13/17)

Disassembling and Assembling

Replacement of Cable

1. Pull the entire length of the cable out of the drum and set stopper pin at a groove and lock drum. In this condition, cable set-bolt must be a set position.
2. Take attached equipment off load hook. (Detach attached equipment after making sure that the drum is locked. Otherwise, there's a danger of the cable will be pulled suddenly if the condition of the lock is insufficient).
3. Remove cable set-bolt and take out cable set from drum.
4. Remove load hook and shock absorber from cable. And exchange damaged or worn-out cable for new one.
5. Fix cable set on drum. The manner of re-assembling of cable set is reversed order of disassembly.
6. Fix cable set-bolt. Mount equipment on load hook and release stopper pin. Do not release stopper pin prior to attaching equipment.

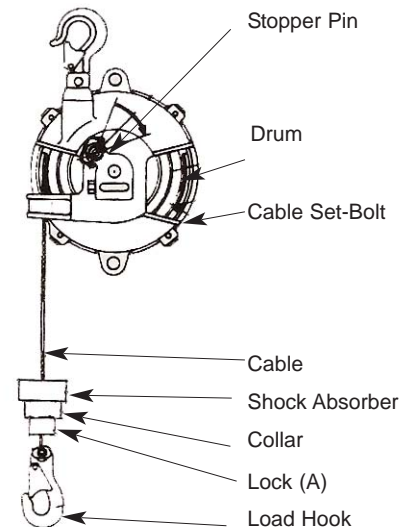

Procedure of Disassembly for Repair

When the tool balancer is to be disassembled, the procedure should be followed.

1. Take attached equipment off the load hook. Then detach tool balancer from trolley, beam or device that it's attached to.
2. Remove gauge.
3. Turn "worm" counterclockwise direction to loosen tension to a low capacity. And remove worm (the worm comes off the case).
4. Remove hex cap bolt and take out safety arm.
5. Remove cable set-bolt and take out cable from drum.
6. Remove casing cover.
7. Take spring case, drum and spindle simultaneously off case.
8. Pull out spindle and take spring case off drum.
9. Take bushing and safety device pin off case.

Procedure of Assembly

1. Install bushing into spring case.
2. Install spindle and spring case on drum.
3. After making sure the stopper pin is not at a position of drum lock, assemble drum, spindle and spring case and set casing cover.
4. Install safety arm. Fasten hex cap screw correctly.
5. After installation thrust washer onto the end of worm. Assemble worm with turning clockwise direction.
6. Install cable. Fix cable set-bolt.

Load and Inspection of Operation

1. Turn worm clockwise direction and wind spiral spring.
2. Suspend tool balancer in position and adjust the tool balancer (adjust the tension).
 - 2.1 Attach equipment on the load hook and adjust tension of the spiral spring by turning the worm to take up the length of stroke of cable. (It's recommended to set the tool balancer at a medium position of tension).
 - 2.2 Install safety device pin, safety device spring and safety device screw. The upper surface of the safety device spring screw should be adjusted to the same level of surface spring case.
 - 2.3 Attach gauge. Adjust the indication of gauge with lading weight.

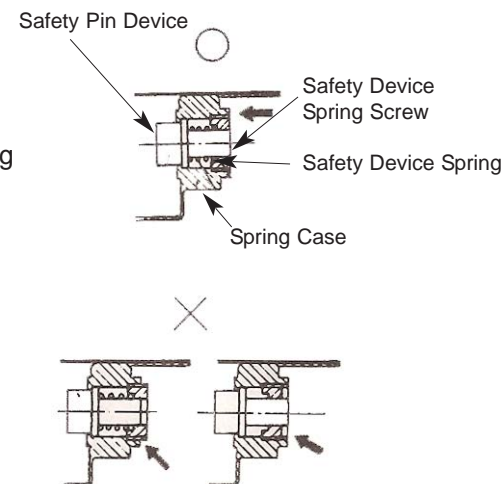

Balancer Operation Instructions (MZ-20 through MZ-154 models)

Rev 2.2 (4/13/17)

Maintenance and Inspection

For the purpose of preventing of accidental falling, inspection should be carried out at least one time monthly.

1. Make sure the bolts of the respective parts are not loosened.
2. Make sure the top hook and load are not worn-out or damaged.
3. Make sure cable is not torn or worn-out. (Take time to check out the condition of a tear or kink of wire rope and damage of locking part of the end of the cable.)

After Service

1. Make sure safety device operate correctly.
2. In the event that any part of tool balancer is broken or damaged, it should be repaired immediately.

Tips on use of Tool Balancers and Secondly Support Chains

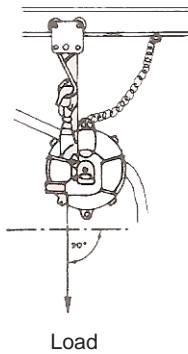

Keep load hanging perpendicular.

WRONG

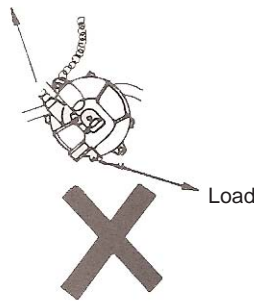

Working with load not perpendicular causes operator fatigue and excessive cable wear and drum wear.

Correct

Tool Balancer loaded on trolley

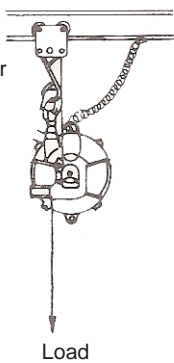

Trolley mount allows balancer to function properly and provides variable work area.

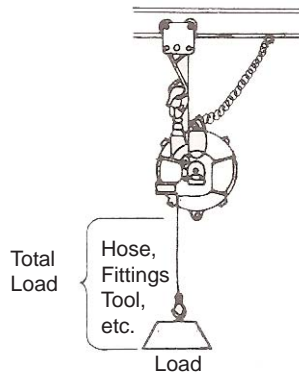

When planning tool balancer installation, consider total balancer load.

Mountz Service Locations

Eastern Service Center

19051 Underwood Rd.
Foley, AL 36535
Phone: (251) 943-4125
Fax: (251) 943-4979

Western Service Center

1080 N.11th Street
San Jose, CA 95112
Phone: (408) 292-2214
Fax: (408) 292-2733

www.mountztorque.com
sales@mountztorque.com



Twitter: @mountztorque

Download a "Service Form" and include a copy when you send the tools in to be serviced.

Looking for fasteners?
www.mrmetric.com

**mr.
metric**