

# MT-6, 9, 50, 80 MicroTorque Screwdriver Parts List

Rev 1.1 4/13/205

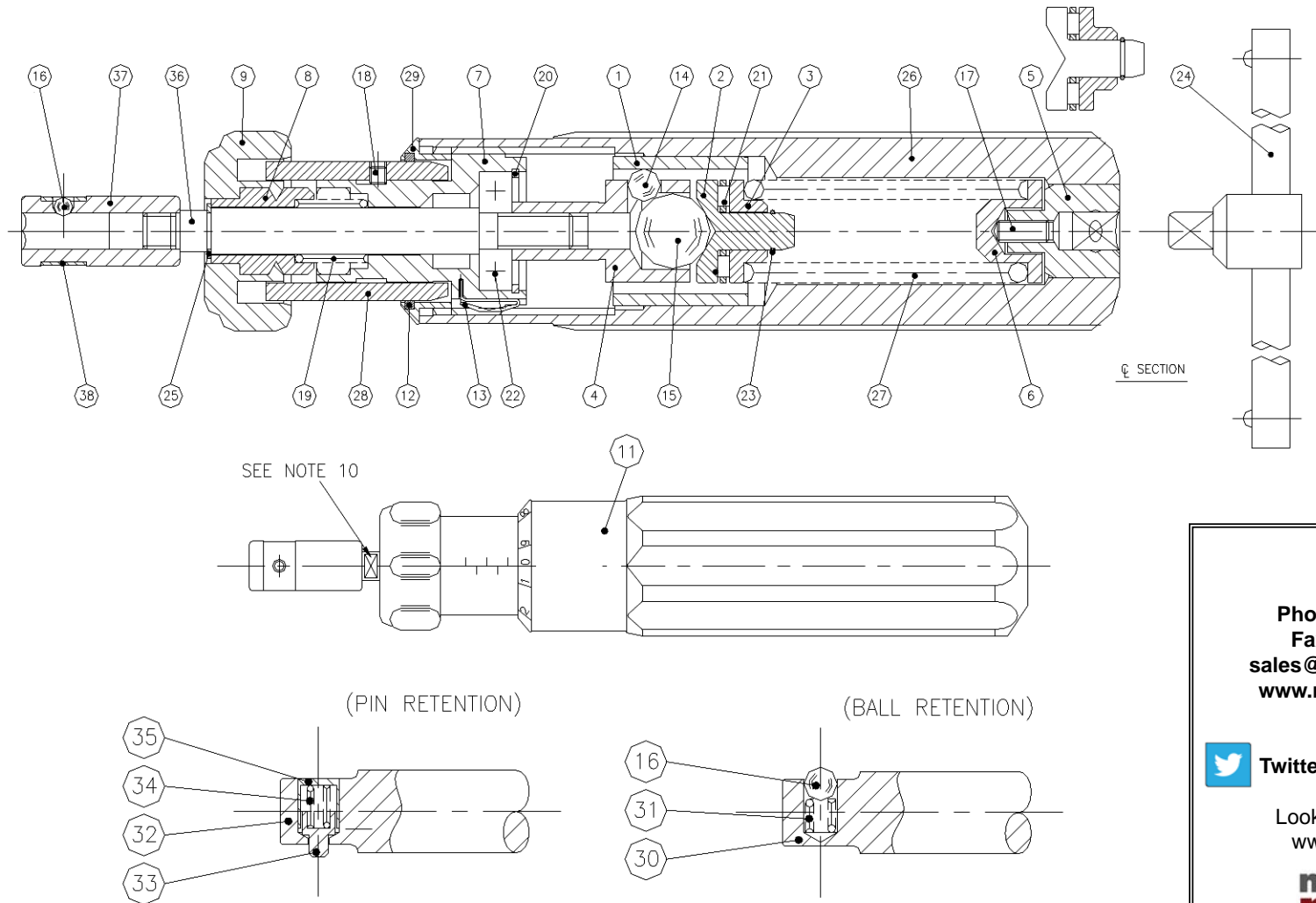

**Contact**  
**Mountz Inc.**  
**Phone: 408.292.2214**  
**Fax: 408.292.2733**  
**sales@mountztorque.com**  
**www.mountztorque.com**

 **Twitter: @mountztorque**

Looking for fasteners?  
[www.mrmetric.com](http://www.mrmetric.com)





# MT-6, 9, 50, 80 MicroTorque Screwdriver Parts List

Rev 1.1 4/13/205

No.	Part #	Description	QTY	Remarks	No.	Part #	Description	QTY	Remarks
1	20-A87300	Cam Ring	1	S/A A56710		20-A70950	Scale Sleeve - Engraving	1	MT5/50
2	20-A11650	Ball pad	1			20-B62930	Scale Sleeve - Engraving	1	MT6/50 Dual
3	20-A11660	Spring pad	1			20-A81960	Scale Sleeve - Engraving	1	MT60K
4	20-A99190	Ball housing	1	S/A 56720		20-A67680	Scale Sleeve - Engraving	1	MT9
5	20-A10740	Square drive insert	1	S/A 56710		20-A70960	Scale Sleeve - Engraving	1	MT40-80
6	20-A56790	Spring seat	1		29	20-A81970	Scale Sleeve - Engraving	1	MT90K
7	20-B99200	Adjusting Screw	1			20-A56820	Bezel	1	Metric
8	20-A56831	Nut	1			20-A57840	Bezel	1	IMP & kg Tools
9	20-B56841	Adjusting grip	1	Includes item 8	30	20-A99220	Spindle - 1/4 Sqare Drive	1	Ball Retention
10	20-A56890	Scale sleeve - Plain	1	See Item 28	31	20-A10031	Ball Catch Spring	1	Ball Retention
11	20-B94661	Tool label	1		32	20-A62950	Spindle - 1/4 Sqare Drive	1	Pin Retention
12	20-A64630	O' Ring Square Section	1		33	20-A64620	Pin	1	Pin Retention
13	20-A76930	Hair Spring	1		34	20-A59850	Spring	1	Pin Retention
14	20-P10580	Steel Ball 7/32in Dia	3		35	20-A59870	Spring Cup	1	Pin Retention
15	20-P10630	Steel Ball 1/2in Dia	1		36	20-A99210	Spindle 1/4 Female Hex	1	Female Hex
16	20-P10650	Steel Ball 1/8in Dia	1		37	20-A10760	Female Hex Body	1	Female Hex
17	20-P23060	SKT Set Screw M5x12Lg	1	S/A A56710	38	20-A56640	Spring Cup	1	Female Hex
18	20-P14580	SKT Set Screw M3x0.5	2						
19	20-P11620	Spring	1						
20	20-P11650	Circlip - Internal	1	S/A A56720					
21	20-P11660	Thrust Bearing	2						
22	20-P22810	Thrust Bearing - Ball Race	1	S/A A56720					
23	20-P23170	Wire Ring	1						
24	20-P14800	T-Bar Assy - 1/4 Square Drive	1						
25	20-P16070	Circlip - External	1						
26	20-B56741	Handle - Red	1	MT6 Varients					
	20-B56742	Handle - Green	1	MT9 Varients					
	20-B56743	Handle - Black	1	MT4, MT4-35					
	20-B56744	Handle - Blue	1	MT3, MT40K					
27	20-A96050	Spring - Metric	1	MT3					
	20-A56850	Spring - Metric	1	MT4, 6, 6/50, 40K, 60K					
	205795	Spring - Imperial	1	MT4-35, MT5-50					
	20-A56880	Spring - Metric	1	MT9, 9/80, 90K					
	20-A57960	Spring - Imperial	1	MT40-80					
28	20-A96040	Scale Sleeve - Engraving	1	MT3					
	20-A96050	Scale Sleeve - Engraving	1	MT4					
	20-A96060	Scale Sleeve - Engraving	1	MT4-35					
	20-A81950	Scale Sleeve - Engraving	1	MT40K					
	20-A58850	Scale Sleeve - Engraving	1	MT6					

Notes:

1. Apply BP06 grease to ball housing (item 4) & cam (item 1)
2. Apply BPLS-EPI brown grease on adjusting screw thread (item 7)
3. Assemble main spring components and insert into handle.
4. Assemble main spring components and insert into handle
5. Assemble handle (item 26) and bezel (item 29) using loctite 243
6. When correct position of scale sleeve (item 28) has been determined 2 off grub screw (item 18) to be tightened to 60-64 ozf.in
7. Seal socket set screws (items 17 & 18) after calibration
8. Assemble spindle (1/4" F/HEX) item 36 and F/Hex Body (item 37) where applicable, use Loctite 648
9. Tee bar assembly (item 24) is supplied with tool
10. Close fitting open end spanner to be used when tightening to avoid damage to flats.