

PSE150 Parts List

January 25, 2012

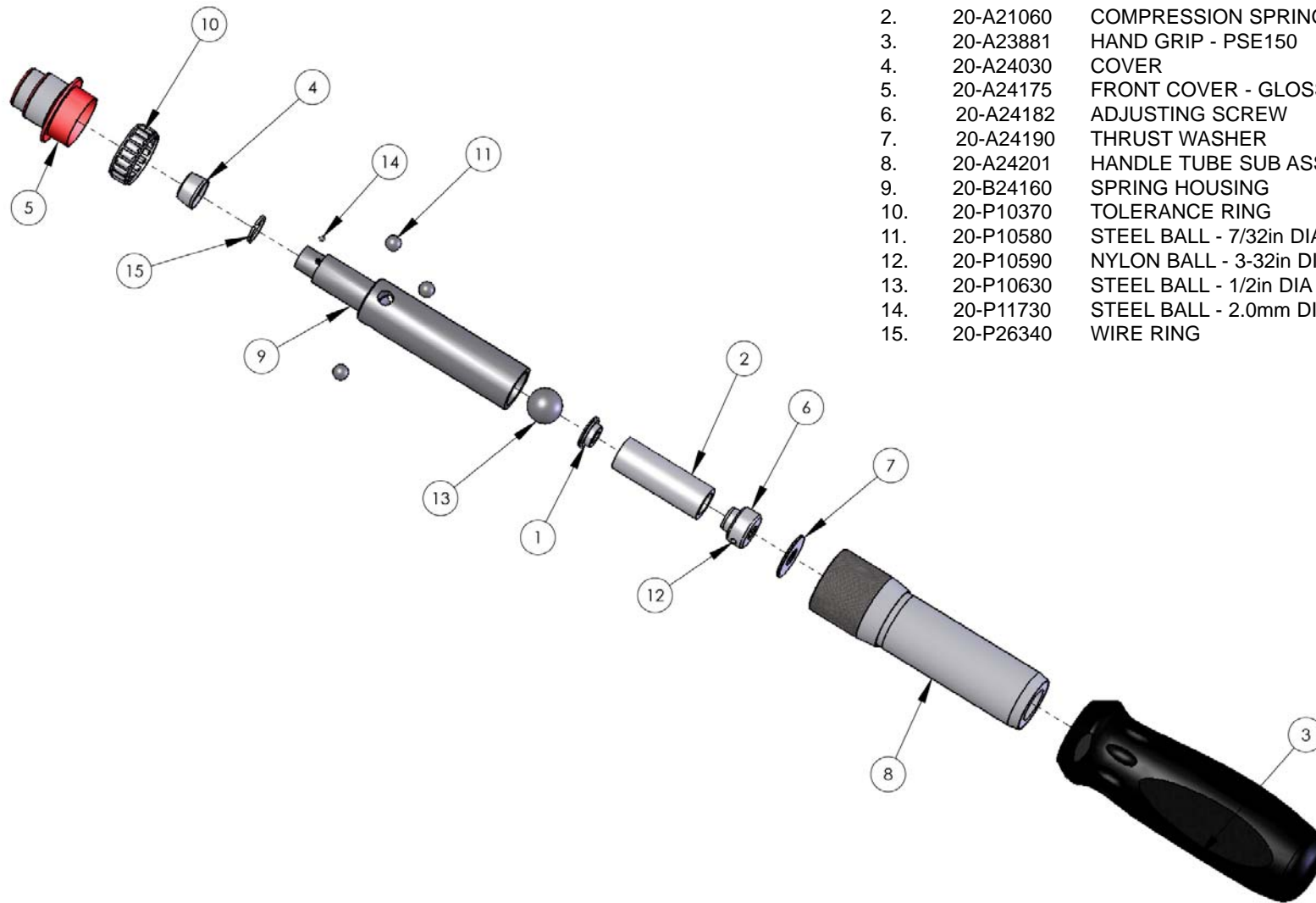

No.	Part Number	Description	Qty.
1.	20-A15700	SPRING THRUST PAD	1
2.	20-A21060	COMPRESSION SPRING	1
3.	20-A23881	HAND GRIP - PSE150	1
4.	20-A24030	COVER	1
5.	20-A24175	FRONT COVER - GLOSS RED	1
6.	20-A24182	ADJUSTING SCREW	1
7.	20-A24190	THRUST WASHER	1
8.	20-A24201	HANDLE TUBE SUB ASSEMBLY	1
9.	20-B24160	SPRING HOUSING	1
10.	20-P10370	TOLERANCE RING	1
11.	20-P10580	STEEL BALL - 7/32in DIA	3
12.	20-P10590	NYLON BALL - 3-32in DIA	1
13.	20-P10630	STEEL BALL - 1/2in DIA	1
14.	20-P11730	STEEL BALL - 2.0mm DIAL	1
15.	20-P26340	WIRE RING	1