

TT250 & TT500 Parts List

Rev. 2 (3/24/2015)

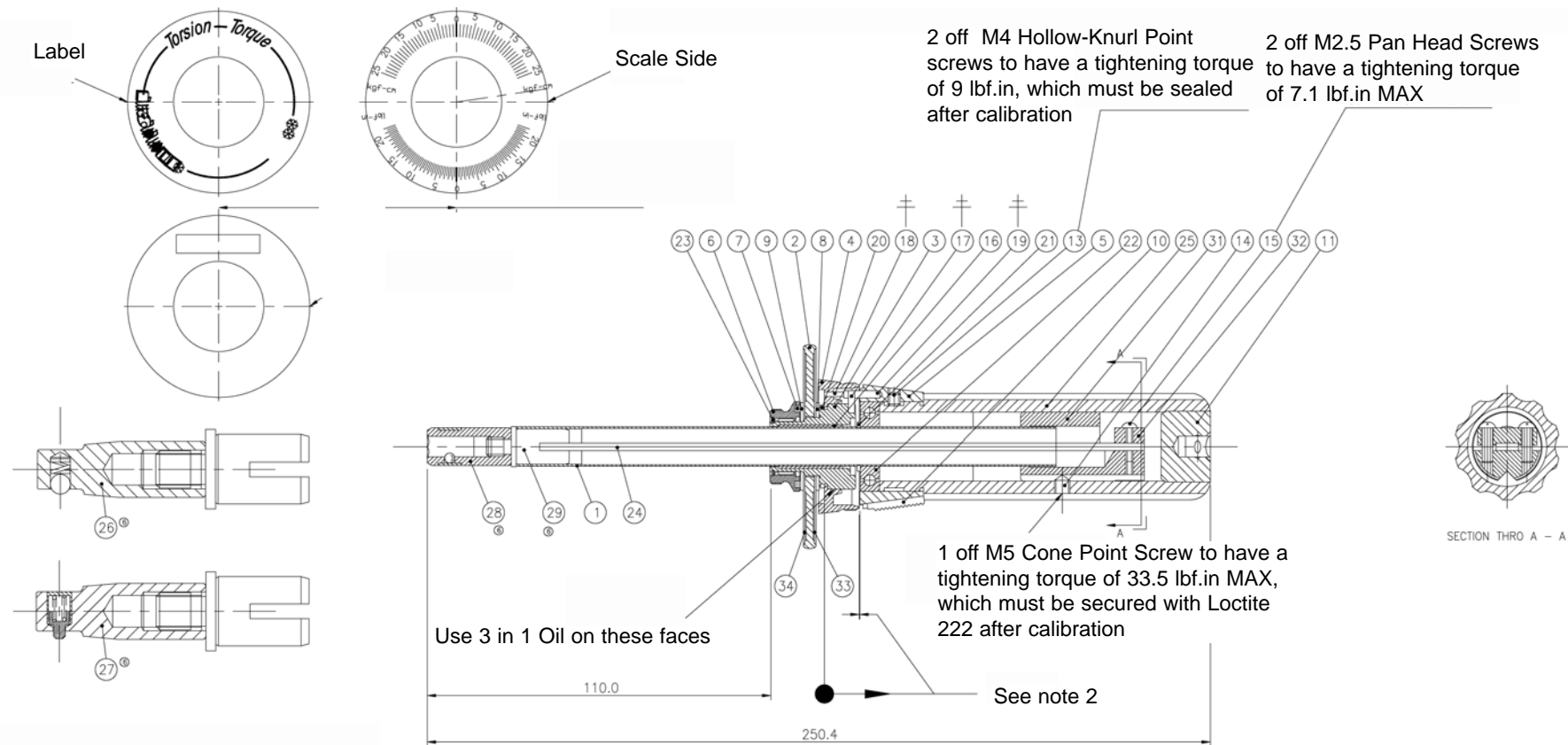

Notes:

1. Items 1 & 29 (1/4 Female Hex) & 1 & 27 (1/4 Square Drive End) to be assembled using Loctite 648 adhesive must be cured before testing.
2. 0.13/.20 to be maintained between fixed bezel when indicator bezel is pulled hard back against shoulder in direction indicated by arrow.
3. Check over load stop pins at 125% of full scale torque
4. Bezel Residual torque to be 0.5 - 0.8 cN.m



TT250 & TT500 Parts List

Rev. 2 (3/24/2015)

No.	Part Number	Description	Qty.	Remarks	No.	Part Number	Description	Qty.	Remarks
1	20-B70090	Shaft Tube	1		33	20-C79400	Dial Label	1	TT250
2	20-B82070	Dial Blank	1			20-C81930	Dial Label	1	TT25K
3	20-C86440	Stop Collar	1			20-C80700	Dial Label	1	TT500
4	20-C75290	Indicator Bezel	1			20-C81940	Dial Label	1	TT50K
	20-A75280	Indicator Bezel	1	Engraving Detail	34	20-C72900	Tool Label	1	TT250
5	20-B75300	Fixed Bezel	1			20-C72910	Tool Label	1	TT500
6	20-B86490	Clamp Nut	1						
7	20-A78822	Wave Spring	1						
8	20-A78812	Fibre Washer	1						
9	20-A78802	PTFE Washer	1						
10	20-B84202	Slider	1						
11	20-A70110	Square Drive Adaptor	1						
13	20-P16200	Socket Set Screw M4x4	2	Hollow Knurl Pt					
14	20-P26920	Socket Set Screw M5x6	1	90 Degree Point					
15	20-P17880	Pan Head Screw	2						
16	20-P18130	Tolerance Ring	1						
17	20-P14680	Spring Pin	2						
18	20-P15460	Spring Pin	1						
19	20-P13530	Spring Pin	1						
20	20-P15710	Retaining Ring	1						
21	20-P15700	Circlip	1						
22	20-P14760	Ball Bearing	1						
23	20-P18230	Retaining Ring	1						
24	20-A69862	Torsion Bar	1	TT250					
	20-A69862	Torsion Bar	2	TT500					
25	20-B75251	Handle Gold	1						
	20-B75252	Handle Green	1						
26	20-A17930	Square Drive Adapter Assembly (Ball)	1	TT500/250					
27	20-A17940	Square Drive Adapter Assembly (Pin)	1	TT500/250					
28	20-A11380	F/Hex Drive Adapter	1	TT500/250					
29	20-A10791	F/Hex Drive End	1	TT250					
	20-A10792	F/Hex Drive End	1	TT500					
31	20-B70161	Clamp Sleeve	1	TT250					
	20-B70162	Clamp Sleeve	1	TT500					
32	20-A70171	Clamp Plate	1	TT250					
	20-A70172	Clamp Plate	1	TT500					

Contact
Mountz Inc.
Phone: 408.292.2214
Fax: 408.292.2733
sales@mountztorque.com
www.mountztorque.com

 **Twitter: @mountztorque**

Looking for fasteners?
www.mrmetric.com

**mr.
metric®**