

TT50 & TT100 Parts List

Rev. 2 (3/24/2015)

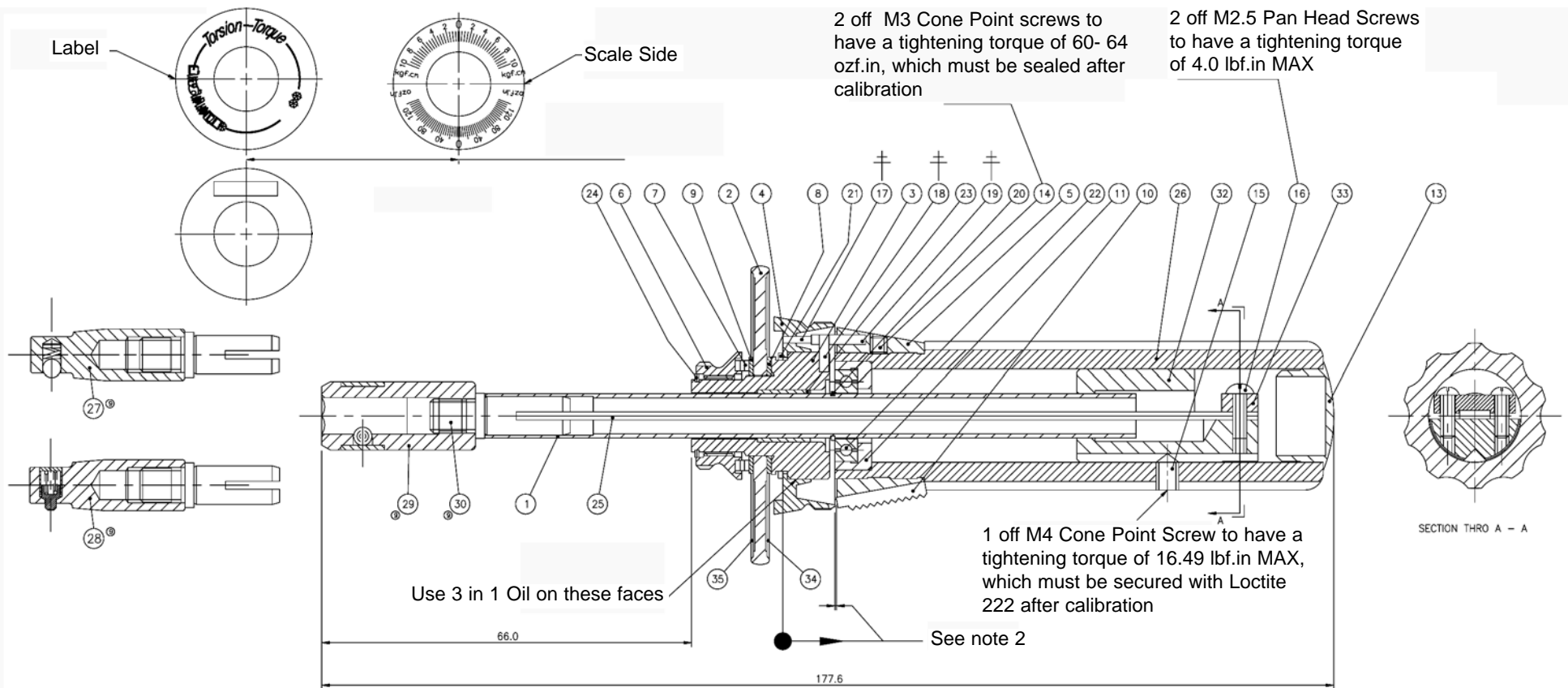

Notes:

1. Items 1 & 29 (1/4 Female Hex) & 1 & 27 (1/4 Square Drive End) to be assembled using Loctite 648 adhesive must be cured before testing.
2. 0.13/.20 to be maintained between fixed bezel when indicator bezel is pulled hard back against shoulder in direction indicated by arrow.
3. Check over load stop pins at 125% of full scale torque
4. Bezel Residual torque to be 0.5 - 0.8 cN.m



TT50 & TT100 Parts List

Rev. 2 (3/24/2015)

| No. | Part Number | Description | Qty. | Remarks | No. | Part Number | Description | Qty. | Remarks |
|-----|-------------|-------------------------|------|------------------|-----|-------------|-------------|------|---------|
| 1 | 20-B75180 | Shaft Tube | 1 | | 34 | 20-C79390 | Dial Label | 1 | TT50 |
| 2 | 20-B82060 | Dial Blank | 1 | | | 20-C81910 | Dial Label | 1 | TT5K |
| 3 | 20-C86430 | Stop Collar | 1 | | | 20-C80690 | Dial Label | 1 | TT100 |
| 4 | 20-C75220 | Indicator Bezel | 1 | | | 20-C81920 | Dial Label | 1 | TT10K |
| | 20-A75210 | Indicator Bezel | 1 | Engraving Detail | 35 | 20-C72880 | Tool Label | 1 | TT50 |
| 5 | 20-B75230 | Fixed Bezel | 1 | | | 20-C72890 | Tool Label | 1 | TT100 |
| 6 | 20-B78780 | Clamp Nut | 1 | | | | | | |
| 7 | 20-A78821 | Wave Spring | 1 | | | | | | |
| 8 | 20-A78811 | Fibre Washer | 1 | | | | | | |
| 9 | 20-A78801 | PTFE Washer | 1 | | | | | | |
| 10 | 20-B84201 | Slider | 1 | | | | | | |
| 11 | 20-A75420 | Bearing Sleeve | 1 | | | | | | |
| 13 | 20-P14710 | End Cover - Plastic | 1 | | | | | | |
| 14 | 20-P11080 | Socket Set Screw | 2 | Hollow Knurl PT | | | | | |
| 15 | 20-P14730 | Socket Set Screw | 1 | 90 Deg Point | | | | | |
| 16 | 20-P14930 | Pan Head Screw | 2 | | | | | | |
| 17 | 20-P15650 | Spring Pin | 1 | | | | | | |
| 18 | 20-P15660 | Spring Pin | 2 | | | | | | |
| 19 | 20-P15670 | Spring Pin | 1 | | | | | | |
| 20 | 20-P15690 | Plain Wire Ring | 1 | | | | | | |
| 21 | 20-P15720 | Retaining Ring | 1 | | | | | | |
| 22 | 20-P15730 | Ball Bearing | 1 | | | | | | |
| 23 | 20-P18120 | Tolerance Ring | 1 | | | | | | |
| 24 | 20-P18210 | Retaining Ring | 1 | | | | | | |
| 25 | 20-A69861 | Torsion Bar | 1 | | | | | | |
| | 20-A69861 | Torsion Bar | 2 | TT50 | | | | | |
| 26 | 20-B75171 | Handle-Gold | 1 | TT100 | | | | | |
| | 20-B75172 | Handle - Blue | 1 | TT50 | | | | | |
| 27 | 20-A17930 | Square Drive End (Ball) | 1 | TT100 | | | | | |
| 28 | 20-A17940 | Square Drive End (Pin) | 1 | TT50 | | | | | |
| 29 | 20-A11380 | F/Hex Drive Adaptor | 1 | | | | | | |
| 30 | 20-A10811 | Drive End | 1 | TT50 | | | | | |
| | 20-A10812 | Drive End | 1 | TT100 | | | | | |
| 32 | 20-B69901 | Clamp Sleeve | 1 | TT50 | | | | | |
| | 20-B69902 | Clamp Sleeve | 1 | TT5K | | | | | |
| 33. | 20-A69911 | Clamp Plate | 1 | TT100 | | | | | |
| | 20-A69912 | Clamp Plate | 1 | TT10K | | | | | |

Contact
Mountz Inc.
Phone: 408.292.2214
Fax: 408.292.2733
sales@mountztorque.com
www.mountztorque.com

 **Twitter: @mountztorque**

Looking for fasteners?
www.mrmetric.com

**mr.
metric®**